



NSK LINEAR GUIDES
REFERENCE GUIDE FOR ALL
INTERCHANGEABLE SERIES
STANDARD PRODUCTS



SUBSCRIBE TO NSK NEWSLETTER 

CONTENTS

Features.....	3
Linear Guides Interchange.....	4
K1™ Maintenance-Free Lubrication Unit	6
K1™ Identification Number	7
K1™ Lubrication Unit Handling and Assembly Instructions	8
Types of Linear Guides	9
Selection	10
Features of NH and NS Series.....	14
NH Series	
Interchangeable Type Nomenclature	16
Linear Guide and Rail Nomenclature.....	16
Accessories.....	17
Dimension Tables.....	18
NS Series	
Interchangeable Type Nomenclature	22
Linear Guide and Rail Nomenclature.....	22
Accessories.....	23
Dimension Tables.....	24
LW Series	
Features.....	28
Interchangeable Type Nomenclature	29
Linear Guide and Rail Nomenclature.....	29
Accessories.....	29
Dimension Tables.....	30
PU/PE Series	
Features.....	32
Interchangeable Type Nomenclature	33
Linear Guide and Rail Nomenclature.....	33
Accessories.....	33
Dimension Tables.....	34
RA Series	
Features.....	36
Interchangeable Type Nomenclature	37
Linear Guide and Rail Nomenclature.....	37
Accessories.....	37
Dimension Tables.....	38
Assembly and Mounting.....	42
Grease.....	44
Application Sheet: Linear Guide - Rail Butting.....	48

This catalog represents the NSK quick ship interchangeable product. NSK offers many additional options beyond this content. Please contact NSK for additional information.

CAD DRAWING DATA

- Use SolidComponents™, a NSK partner, to easily access files for standard stock NSK Linear Guide Products including NH, NS, LW, PU/PE and RA Series.
 - Visit <http://npa.solidcomponents.com> to download all CAD files and technical information.
- Note: CAD DXF drawing files are also available for other NSK Linear Motion Products.

FEATURES

Use this guide to select the linear guides, rails and accessories for your specific application. This reference guide has been created to serve as the preferred resource for all **standard stock, quick ship** NSK Linear Guides. If you're seeking a custom solution, please contact NSK. You can also reference Precision Machine Components (E3162) for a comprehensive listing of **all NSK Linear Guide** manufactured products.

Interchangeability of Rail and Ball Slide

One important manufacturing feature of the Gothic Arch is the ability to make highly accurate measurements on both the ball slide and rail, allowing for tight tolerance control, resulting in interchangeability. This means that additions and/or replacement of ball slides is easily done.

High Load Capacity and Long Life

NSK has developed a ball recirculating type linear guide with the largest load capacity available (comparing equal size ball slides). This high load capability helps to ensure long life.

Miniature and Miniature Wide Type Stainless Steel

If light loads and corrosive conditions are present for your application needs, NSK can supply a miniature and miniature wide type linear guide in stainless steel. NSK's built-in ball retainer system allows for easy installation and removal of ball slides.

Wide Type

If your application requires low profile combined with high load, NSK offers the wide series linear guides.

Roller Guide

The RA series comes in an interchangeable offering with medium preload. NSK has incorporated roller bearing technology which provides super high load capacity and rigidity.

Shock Resistant Design

Another design feature of the Gothic Arch is its ability to absorb vertical shock loads from above using four-row groove configuration. This design is favorable in case of unexpected accidents during installation, or the operation of equipment. The ball groove is designed to avoid edge loading under extreme loads, extending the life of the unit.

Universal Slider

NSK has incorporated both thru and tapped holes into one flanged slider for a combination of mounting applications (EM/EMZ and GM/GMZ).

Ability to Butt Rails

Tolerance of ball/roller grooves on the sliders, rails and rail end cuts are controlled to allow for butting, giving you the flexibility of unlimited lengths. We offer a stocked linear guide rail with versatility in assembling different lengths.

K1™ Maintenance-Free Lubrication Units

NSK has K1™ Lubrication Units available from stock for all six series of the interchangeable linear guides. K1™ Lubrication Units deliver maintenance-free operation. Each unit will not require maintenance for up to 5 years or 10,000 km depending on operational conditions. Longer lubricating life can be achieved dependent on application. For more information, contact NSK.

Maximum Rail Length in One Section Available up to 4,000mm. Short Delivery Time.

We can ship from our large inventory, both standard and custom cut-to-length linear rails.

Armoloy™ Chrome Plating

Armoloy™ sliders and rails available on NH, NS, and LW types for conditions requiring wet, corrosive and clean room applications. Contact NSK for lead times.

Protector Plate

NSK sliders can be custom configured to include an optional protector plate to remove debris like weld flash from the rail and prevent contamination from entering the slider.

Rail Caps

NSK offers plastic or brass rail caps to prevent debris build-up in the rail mounting holes.

LINEAR GUIDES INTERCHANGE

Description	Interchange																																														
	NSK				THK				THOMSON				SKF				BOSCH - REXROTH (STAR)				INA																										
Carriage Part Number	NAH	20	AN	Z	HSR	20	R	C1	511	H	20	C	1	LLRHC	20	A-	T1	R1651	-	8	1	4	-	10	KWVE	20	-	B-H	G4	V2																	
	1	2	3	7	1	2	3	7	1	6	2	3	7	1	2	3	7	1,3	-	2	7	6	-	8	1	2	3	7	8																		
Rail Part Number	N1H	20	XXXX	Z	HSR	20+	XXXXL	521	H	20	A	+XXXX	LLRHR	20x	XXXX	P5	R1605	-	4	0	4	-	XXXX	TKVD	20	-	G4	/	XXXX																		
	1	2	4	7	1	2	4	6	1	6	2	4	1	2	4	6	1,4	-	2	X	6	-	4	1																							
Assembly Part Number	NH	25	XXXX	AN	C	X	PC	Z	HSR	20	R	2	SS	C1	+XXXXL																																
	1	2	3	4	5	6	7	8	1	2	3	5	8	7	4	6								N/A				LLRHS	20	A	2	T1	XXXX	P5	N/A				KUVE	20	-	B-H	W2	G4	V2	/	XXXX
	1	2	3	4	5	6	7	8	1	2	3	5	8	7	4	6								1	2	3	6	7	8			1	2	3	6	7	8										

The competitive manufacturers are provided for a convenient source of unit substitution. They can be considered interchangeable in most instances, but for special applications, please consult NSK Engineering. NSK assumes no liability with respect to errors or omissions.

1 - Linear Guide Series

NSK	THK	THOMSON		SKF	BOSCH - REXROTH (STAR)	INA
		Old	New			
NH	HSR (SHS)	CG	511	LLRHS/LLTHS	R16 ¹	KUVE##/KWVE##/TKVD## ²
NS	SR (SSR)			LLRHS	R161	KUVE##/KWVE##/TKVD## ²
LW	HRW				R1671	KUVE##-WKWVE##-W/TKVD##-W
PU	RSR	CD	TSR-Z	LLMHS	R0442/R0444	KUEM##/KWEM##/TKDM##
PE	RSR W	LLMWS	TSR-WZ	LLMWS	R0441/R0443	KUEM##-W/KWEM##-W/TKDM##-W

¹ See Carriage Section for Exact Series for Bosch - Rexroth (STAR)

² See Carriage and Rail Section for Exact Series for INA

2 - Linear Guide Series (rail width)

NSK	THK	THOMSON	SKF	BOSCH - REXROTH (STAR)	INA
Number indicated rail width	Same as NSK	Same as NSK with the exception of the CD series	Same as NSK	See Table	Same as NSK

BOSCH - REXROTH (STAR)		
Series	BOSCH Size	NSK Size
R16##	1	15
R16##	8	20
R16##	2	25
R16##	7	30
R16##	3	35
R16##	4	45
R16##	5	55
R16##	6	65
R1671	5	27
R1671	2	35
R1671	3	50
R044#	7	07
R044#	8	09
R044#	2	12
R044#	5	15

3 - Linear Guide Carriage Styles ## = size (rail width)

NSK	THK		THOMSON		SKF	BOSCH - REXROTH (STAR)	INA
	Common	Less Common	Old	New			
NAH##AN	HSR##R (SHS##R/V)	HSR##TR/TRX/CR	CG##CE	511H##E	LLRHC##R/U (20,45)	R1621	KWVE##-B-H
NAH##BN	HSR##LR (SHS##LR/LN)	HSR##HTR/HR	CG##DE	511H##F	LLRHC##LR	R1624	KWVE##-B-HL
NAH##EM	HSR##A/B/CA/CB (SHS##C)	HSR##TA	CG##AA	511H##A	LLRHC##A	R1651	KWVE##-B
NAH##GM	HSR##HA/LA/HB/LB (SHS##LC)	HSR##HTA/HTB	CG##BA	511H##B	LLRHC##LA	R1653	KWVE##-BL
NAH##AL	(SHS##V)			511H##C (25,30,35)	LLRHC##U (25,30,35)	R1622 (except R1622-1)	KWVE##-B-S
NAH##BL	(SHS##LV)			511H##D (25,30,35)		R1623	KWVE##-B-SL
NAS##EM	SR##TB (SSR##XTB)					R1693	
NAS##AL	SR##W (SSR##XW)	SR##TX/WY (SSR##XWY)			LLRHC15U	R1694/R1622-1	
NAS##CL	SR##V (SSR##XV)	SR##SX/VY (SSR##XVY)			LLRHC##SU (15,30,35)	R1662/R1666/R1664	KWVE##-B-ESC
NAS##JM	SR##SB				LLRHC##SA	R1663	KWVE##-B-EC
LAW##EL	HRW##CA/CR					R1671	KWVE##-W
PAU##AR	RSR07M/RSR07N				LLMHC##TA		KWEM##-
PAU##TR	RSR05M/##N (5,9)	RSR09KM/RSR12VM			LLMHC##TA	R0442	KWEM##-
PAU##UR	RSR12N					R0444	KWEM##-L
PAU##AL	RSR15VM						KWEM##-
PAE##AR	RSR05WM/##WN (5,12,15)	RSR12WVM/RSR15WVN			LLMWC##TA	R0443	KWEM##-W
PAE##TR	RSR07WM/##WN (7,9)	RSR09WVM			LLMWC##TA	R0441	KWEM##-WL

4 - Linear Guide Rail Length (mm) ## = size (rail width) XXXX = length

NSK	THK	THOMSON		SKF	BOSCH - REXROTH (STAR)	INA
		Old	New			
N1H##XXXXZ	HSR##+XXXXL	RG##NLXXXX	521H##A+XXXX	LLRHR##xXXXXP5	R1605-###-XXXX ¹	TKVD##-##/XXXX ²
N1S##XXXXZ	SR##+XXXXL			LLRHR##xXXXXP5	R1605-###-XXXX ¹	TKVD##-##/XXXX ²
L1W##XXXXZ	HRW##+XXXXL				R1605-###-XXXX	TKVD##-W-##/XXXX
P1U##XXXXZ	RSR##+XXXXL	RD##HLXXXX	TSR##Z+XXXX	LLMHR##xXXXXP5	R0445-###-XXXX	TKDM##-##/XXX
P1E##XXXXZ	RSR##W+XXXXL		TSR##WZ+XXXX	LLMWR##xXXXXP5	R0455-###-XXXX	

¹ See Carriage Section for Exact Series for Bosch - Rexroth (STAR)

² See Carriage and Rail Section for Exact Series for INA

5 - Carriages

The number following the carriage style equals the number of carriages per rail.

6 - Accuracy Class

NSK	THK	THOMSON	SKF	BOSCH - REXROTH (STAR)	INA
PC (interchangeable)	BLANK	N	P5	4- (N)	G3
P6	H	H	P3	3- (H)	
P5	P	P	P1	2- (P)	G2
P4	SP	S	P01	1- (XP/SP)	G1
P3	UP	U	P001	9- (UP)	

7 - Preload

NSK (Matched Assembly)	THK	THOMSON		SKF	BOSCH - REXROTH (STAR)	INA
		Old	New			
T or Z0	BLANK	A	0	T0	-#9#	
Z or Z1	C1	B	1	T1	-#1#	V1
Z2	C1	B	1	T1	-#2#	V2
H or Z3	C0	C	2	T2	-#3#	V3
Z4	C0	C	3	T3		V4

8 - Seals

NSK	THK	THOMSON		SKF	BOSCH - REXROTH (STAR)	INA
		Old	New			
Standard (End Seals)	UU-End Seals			Standard	Standard	-10 or -20 or -22
Standard (Side Seals)	SS-Side Seals+End Seals	LDS		Standard	Standard	-10 or -20 or -22
-P (Protector/Scraper)	ZZ-End, Side, Inner Seals and Scraper	ZZ	Z	S1	None	Separate Part Numbers
-D (Double End Seals)	DD-Double End, Side, and Inner Seals	DD	W	S2	None	
-DP (Double End Seals, Protector)	KK-Double End, Side, Inner Seals and Scraper	KK	WZ	S3	None	

Lubrication Systems

NSK	THK	THOMSON	SKF
-K1™	QZ	LL	Standard
External to the Carriage	External to the Carriage	External to the Carriage	Internal Foam Insert

K1™ MAINTENANCE-FREE LUBRICATION UNIT

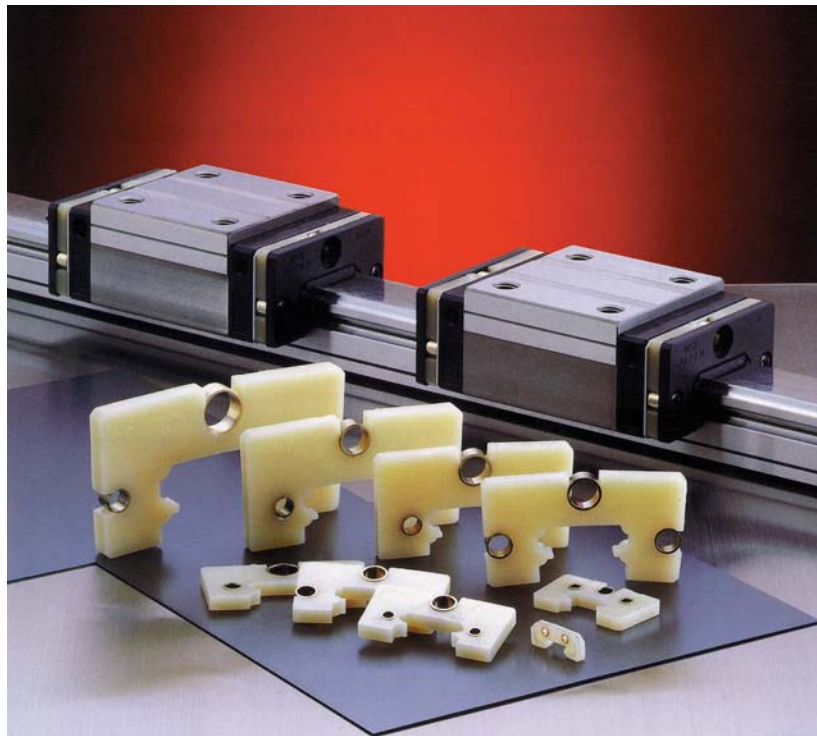

The NSK K1™'s distinctive capabilities as a compact and efficient oil-impregnated lubrication unit as well as a seal, greatly increases the performance of the Linear Guide. The K1™ lubrication unit is available in two types, one for industrial applications and one for food and medical devices where cleanliness and safety are paramount.

FEATURES:

1. Long-term, maintenance-free usage.

NSK K1™ Lubrication Units do not require maintenance for up to 5 years or 10,000 km depending on operational conditions. Units can be replaced in the field if needed. Longer, operating lubricating life can be achieved by using multiple K1 units. For more information, please contact NSK.

2. Prevention of oil-related environmental pollution.

In locations where oil greatly affects the environment, or in mechanisms with no drip/severe hygiene restrictions, sufficient lubrication is provided using the NSK K1™ in combination with grease.

3. Effective in environments where the lubricant is washed away.

In facilities where mechanisms are washed down with water, or subject to severe environment conditions, long service life is ensured by using the NSK K1™ in combination with grease.

4. Maintains efficiency in dusty environments.

In environments where oil and grease-absorbing dust is produced, long-term efficiency is maintained by using the NSK K1™ in combination with grease.

K1™ IDENTIFICATION NUMBER

Refer to the following numbering system when ordering.

NA	H	30	AN	Z	-	K1
INTERCHANGEABLE BALL SLIDE	SERIES CODE	SIZE	BALL SLIDE SHAPE CODE	PRELOAD Z: Light preload Blank: Clearance type		NSK K1™ EQUIPPED

Interchangeable Linear Guide Dimensions - NH, NS, LW, PU, PE, RA Series

Unit: mm

Interchangeable Ball/Roller Slide Size Code	Ball/Roller Slide Form		Standard Ball/Roller Slide Length	Ball/Roller Slide Length with two NSK K1™ L	Thickness of NSK K1™ V ₁	Thickness of Backing Plate V ₂	Grease Fitting Projection N (mm)
NAH15	AN	EM	55.0	65.6	4.5	0.8	5
NAH20	AN	EM	69.8	80.4	4.5	0.8	14
NAH25	AN/AL	EM	79.0	90.6	5.0	0.8	14
NAH30	AN/AL	EM	85.6	97.6	5.0	1.0	14
NAH35	AN/AL	EM	109.0	122.0	5.5	1.0	14
NAH45	AN	EM	139.0	154.0	6.5	1.0	15
NAH55	AN	EM	163.0	178.0	6.5	1.0	15
NAH65	AN	EM	193.0	211.0	8.0	1.0	16
NAS15	AL	EM	56.8	66.4	4.0	0.8	5
NAS20	AL	EM	65.2	75.8	4.5	0.8	14
NAS25	AL	EM	81.6	92.0	4.5	0.8	14
NAS30	AL	EM	96.4	108.4	5.0	1.0	14
NAS35	AL	EM	108.0	121.0	5.5	1.0	14
LAW17	EL		51.4	61.6	4.5	0.6	5
LAW21	EL		58.8	71.4	5.5	0.8	13
LAW27	EL		74.0	86.6	5.5	0.8	13
LAW35	EL		108.0	123.0	6.5	1.0	13
LAW50	EL		140.6	155.6	6.5	1.0	14
PAU09	AR	TR	30.0	36.4	2.7	0.5	-
PAU12	AR	TR	35.2	42.2	3.0	0.5	-
PAU15		AL	43.0	51.2	3.5	0.6	-
PAE09	AR	TR	39.8	46.8	3.0	0.5	-
PAE12	AR		45.0	53.0	3.5	0.5	-
PAE15	AR		56.6	66.2	4.0	0.8	-
RA25	AN	AL	97.5	107.5	5.0	3.3	11
RA30	AN	AL	110.8	122.8	6.0	3.6	11
RA35	AN	AL	123.8	136.8	6.5	3.6	11
RA45	AN	AL	154.0	168.0	7.0	4.2	14
RA55	AN	AL	184.0	198.0	7.0	4.2	14
RA65	AN	EM	228.4	243.4	7.5	5.5	14
	BN	GM	302.5	317.5			

NH/NS Series

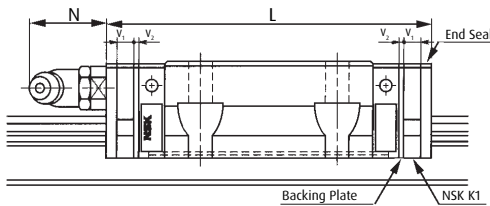

LW Series

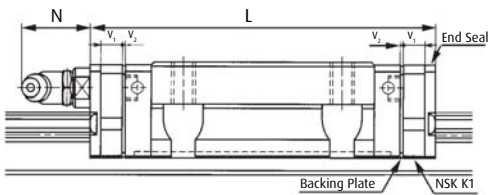

PU/PE Series

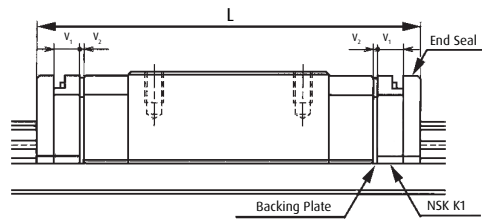

RA Series

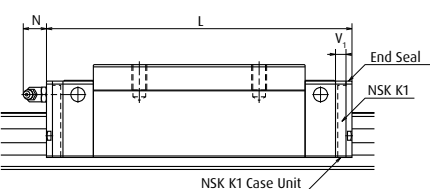

K1™ LUBRICATION UNIT HANDLING AND ASSEMBLY INSTRUCTIONS

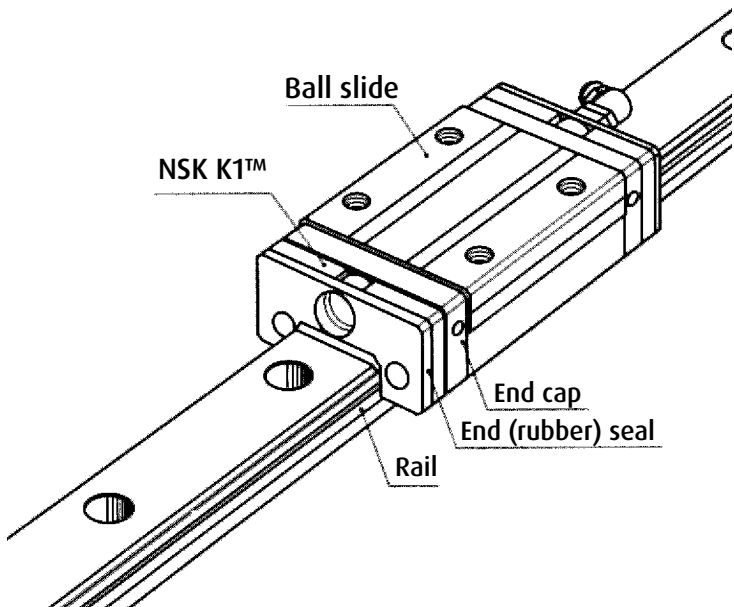

HANDLING INSTRUCTIONS

To maintain the NSK K1™ unit's high efficiency over a long period of time, please follow these instructions:

1. Permissible temperature range Max. operating temperature: 50°C (122°F) Max. peak temperature: 80°C (176°F).
2. Never leave the linear guide in close proximity to grease-removing organic solvents such as hexane, thinners, etc.

Never immerse the linear guide in kerosene or rust preventative oils which contain kerosene.







Note

Other oils such as: water-based cutting oil, oil-based cutting oil, grease (mineral oil-AS2, ester-PS2) present no problems to the K1™ lubricating unit's performance.

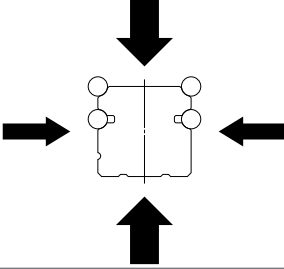
ASSEMBLY INSTRUCTIONS FOR THE K1™ LUBRICATING UNIT FOR LINEAR GUIDES

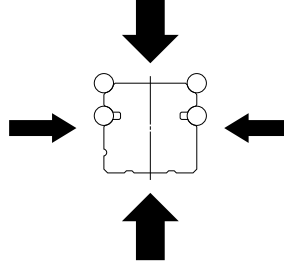
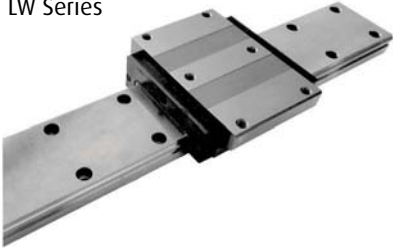
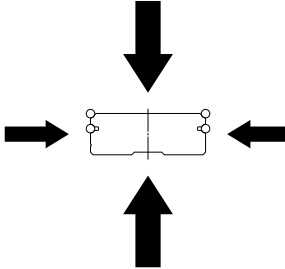
1. Slide linear bearing on to the linear rail, using the plastic provisional rail supplied.
2. Remove the grease fitting from the end of the bearing.
3. Remove the Phillips screws (2 pieces).
4. Remove the end seal from end of bearing.
5. Install threaded plug from K1™ kit (or see option 9 and 10 depending on application).
6. Install the backing plate from the K1™ kit, to the end of bearing, against the end cap.
7. Install K1™ lubricating unit without fixing rings, so it can be expanded over the rail.
8. Put the three (3) fixing rings in position on the K1™ lubricating unit.
9. Replace the end seal, in front of the K1™ lubricating unit.
10. Install connector screw for grease fitting.
11. Replace the grease fitting in connector screw.
12. Install the extension Phillips screws (2 pieces, supplied with the K1™ unit kit).

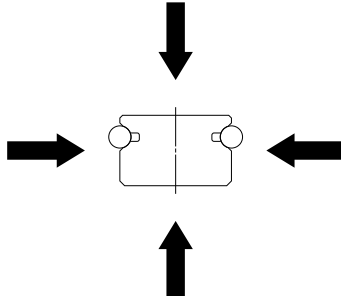
TYPES OF LINEAR GUIDES

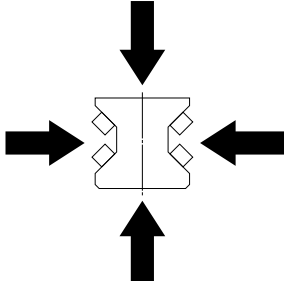
Appearance	Load Carrying Characteristics	Major Applications
<p>NH Series*</p> 	<p>High vertical load carrying capacity</p> 	<ul style="list-style-type: none"> • Industrial robots • Materials handling equipment • Semiconductor manufacturing equipment • Laser cutting machines • Electric discharge machines • Packaging/packing machines
<p>NS Series*</p> 	<p>High vertical load carrying capacity</p> 	<ul style="list-style-type: none"> • Industrial robots • Materials handling equipment • Electric discharge machines • Woodworking machines • Semiconductor manufacturing equipment • Packaging/packing machines • Pneumatic equipment
<p>LW Series</p> 	<p>High vertical load carrying capacity</p> 	<ul style="list-style-type: none"> • Industrial robots • Materials handling equipment • Electric discharge machines • Woodworking machines • Semiconductor manufacturing equipment • Packaging/packing machines • Pneumatic equipment
<p>PU/PE Series</p> 	<p>Four-way equal load carrying capacity</p> 	<ul style="list-style-type: none"> • Semiconductor manufacturing equipment • LCD manufacturing equipment • Medical equipment • Optical stages • Microscope XY stages • Miniature robots • Pneumatic equipment • Computer peripherals
<p>RA Series</p> 	<p>Four-way equal load carrying capacity</p> 	<ul style="list-style-type: none"> • Machining centers • NC lathes • Heavy cutting machine tools • Various types of NC grinders • Gear-cutting machines • Press machines • Electric discharge machines

*The NH/NS series are interchangeable with the previous LH/LS series, including the rails and sliders as components.

SELECTION

RADIAL CLEARANCE AND PRELOAD OF INTERCHANGEABLE SERIES

The internal clearance refers to the amount of movement of the ball slide, when moved up and down with the rail fixed. The amount of clearance / preload is specified by size as follows.

Size	Fine Clearance - ZT	Slight Preload - ZZ	Medium Preload - ZH
NH15	-4 ~ 15	-4 ~ 0	-7 ~ -3
NH20	-5 ~ 15	-5 ~ 0	-8 ~ -3
NH25	-5 ~ 15	-5 ~ 0	-9 ~ -4
NH30	-5 ~ 15	-7 ~ 0	-12 ~ -5
NH35	-5 ~ 15	-7 ~ 0	-12 ~ -5
NH45	-5 ~ 15	-7 ~ 0	-14 ~ -7
NH55	-5 ~ 15	-9 ~ 0	
NH65	-5 ~ 15	-9 ~ 0	
NS15	-4 ~ 15	-4 ~ 0	
NS20	-4 ~ 15	-4 ~ 0	
NS25	-5 ~ 15	-5 ~ 0	
NS30	-5 ~ 15	-5 ~ 0	
NS35	-5 ~ 15	-6 ~ 0	
LW17	-3 ~ 15	-3.5 ~ 0	
LW21	-3 ~ 15	-3.5 ~ 0	
LW27	-4 ~ 15	-4 ~ 0	
LW35	-5 ~ 15	-5 ~ 0	
LW50	-5 ~ 15	-7 ~ 0	
PE09TR, PE12AR, PE15AR	0 ~ 3		
PE09UR, PE12BR, PE15BR	0 ~ 5		
PU09TR, PU12TR, PU15AL	0 ~ 3		
PU09UR, PU12UR, PU15BL	0 ~ 5		

Type	Size	Medium Preload Z3
High Load Type	RA25 AN, AL, EM	2920
	RA30 AN, AL, EM	3890
	RA35 AN, AL, EM	5330
	RA45 AN, AL, EM	9280
	RA55 AN, AL, EM	12900
	RA65 AN, AL, EM	21000
Super High Load Type	RA25 BN, BL, GM	3540
	RA30 BN, BL, GM	4760
	RA35 BN, BL, GM	6740
	RA45 BN, BL, GM	11600
	RA55 BN, BL, GM	16800
	RA65 BN, GM	28800

Note: Minus sign denotes that a value is an amount of preload (elastic deformation of balls)

SELECTION (CONT)

ACCURACY STANDARD OF INTERCHANGEABLE SERIES

(For Clearance Preload Type)

Unit = μm

Tolerances (See Figure 1 for Symbols)	Model No. NH		Model No. NS	Model No. LW	Model No. PE / PU	Model No. RA
	15, 20, 25, 30, 35	45, 55, 65	15, 20, 25, 30, 35	17, 21, 27, 35, 50	09, 12, 15	25, 30, 35, 45, 55
Mounting Height H	± 20	± 30	± 20	± 20	± 20	± 20
Variation of Mounting Height H	15 ⁽¹⁾	20 ⁽¹⁾	15 ⁽¹⁾	15 ⁽¹⁾	15 ⁽¹⁾	15 ⁽¹⁾
	30 ⁽²⁾	35 ⁽²⁾	30 ⁽²⁾	30 ⁽²⁾	30 ⁽²⁾	30 ⁽²⁾
Mounting Width W_2	± 30	± 35	± 30	± 30	± 20	± 25
Variation of Mounting Width W_2	25	30	25	25	20	20

W_2 is applicable to the reference side only.

Note: during installation the reference side is indicated by a line provided on the side of the ball slide and rail. (See Figure 1)

⁽¹⁾ Variation on the same rail

⁽²⁾ Variation on multiple rails

Figure 1 - Accuracy Standard

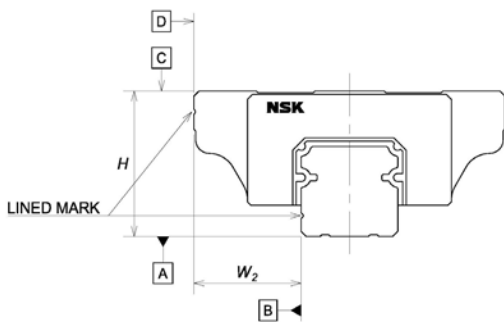

SELECTION (CONT)

RUNNING PARALLELISM OF BALL SLIDE

Unit: μm

Rail length (mm)		NH Series	NS Series	LW Series	PU/PE Series	RA Series
over	or less	Interchangeable				
		Normal grade PC				
						P6
	~50	6.0	6.0	6.0	6.0	4.5
	50 - 80	6.0	6.0	6.0	6.0	5.0
	80 - 125	6.5	6.5	6.5	6.5	5.5
	125 - 200	7.0	7.0	7.0	7.0	6.0
	200 - 250	8.0	8.0	8.0	8.0	7.0
	250 - 315	9.0	9.0	9.0	9.0	8.0
	315 - 400	11.0	11.0	11.0	11.0	9.0
	400 - 500	12.0	12.0	12.0	12.0	10.0
	500 - 630	14.0	14.0	14.0	14.0	12.0
	630 - 800	16.0	16.0	16.0	16.0	14.0
	800 - 1000	18.0	18.0	18.0	18.0	16.0
	1000 - 1250	20.0	20.0	20.0	20.0	17.0
	1250 - 1600	23.0	23.0	23.0	-	19.0
	1600 - 2000	26.0	26.0	26.0	-	21.0
	2000 - 2500	29.0	29.0	29.0	-	22.0
	2500 - 3150	32.0	32.0	32.0	-	25.0
	3150 - 4000	34.0	34.0	34.0	-	30.0*

* Max length = 3500.

LOAD RATINGS AND FATIGUE LIFE

The basic load rating is considered to be a downward load to the slide and is indicated in the dimension tables as the dynamic load rating C and the static load rating C_0 respectively. However, the load may be applied to a slide in upward or lateral directions in actual use. In such a case, contact NSK for this calculation. For RA series the C and C_0 are the same for all load directions.

$$L = 50 \left(\frac{C}{f_w \bullet F} \right)^3$$

- where
- L: Rated fatigue life (km)
 - C: Basic dynamic load rating (N)
 - F: Load to a ball slide (N) (Dynamic equivalent load)
 - f_w : Load factor
 - $f_w=1.0\sim 1.2$ (Smooth condition)
 - $f_w=1.2\sim 1.5$ (Normal condition)
 - $f_w=1.5\sim 3.0$ (With shock or vibration)

NOTES



Lined area for notes, consisting of multiple horizontal lines.

FEATURES OF NH AND NS SERIES

1. Excellent durability

Super-long life, twice as long compared to conventional series

NH and NS series have a load rating 1.3 times greater and a lifespan two times longer than LH and LS Series*1. These features enable you to design a machine with a longer life and/or downsize the machine.

*1: Based on the representative values of each series.

Maintenance-free

Installing NSK K1™ lubrication unit (optional) ensures a long-term, maintenance-free operation, saving cost. Environmental protection can also be achieved.

What is "NSK K1™" lubrication unit?

NSK K1™ is a lubrication device which combines oil and resin in a single unit. The porous resin contains a large amount of lubrication oil. As the linear guide operates, the NSK K1™ provides fresh oil to the contacting surfaces.

2. Easy-to-use "Standard Linear Guides"

Random-matching (interchangeable) type is available

The rails and ball slides can be selected in many combinations. All NH/NS models can be interchanged with LH and LS Series, respectively. Free combination of different ball slide types, accuracy grades, and preload can be made.

Robust design to absorb mounting errors

The DF combination results in a high self-aligning capability. This increases the capacity to absorb errors in installation, and will demand less work to achieve precision in mounting the linear guide.

Options

Accessory options are available, including NSK K1™ lubrication units, double seals, protectors, surface treatments, etc.

Mounting dimensions are the same as the LH and LS Series

NH and NS are completely interchangeable with LH and LS and can be used without making any design modifications.

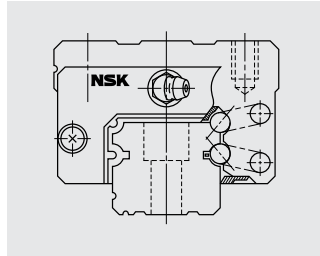

NH Series
Larger load rating capacity



NS Series
Compact, low-profile shape

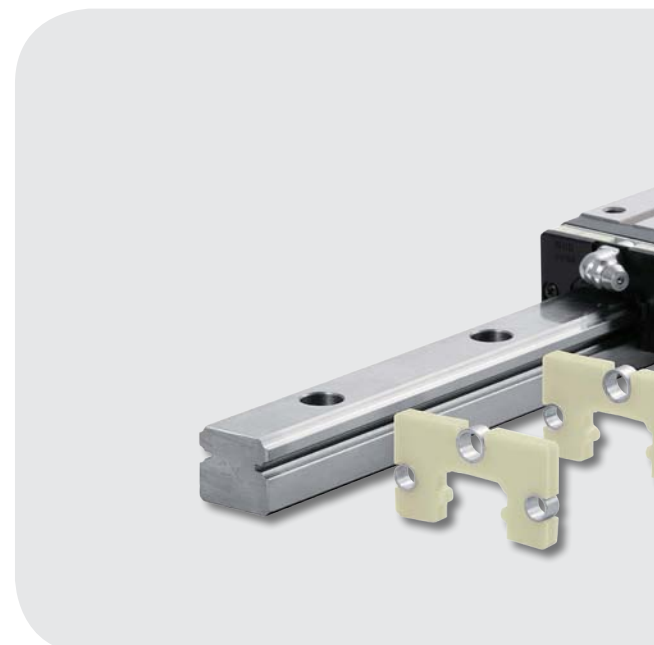

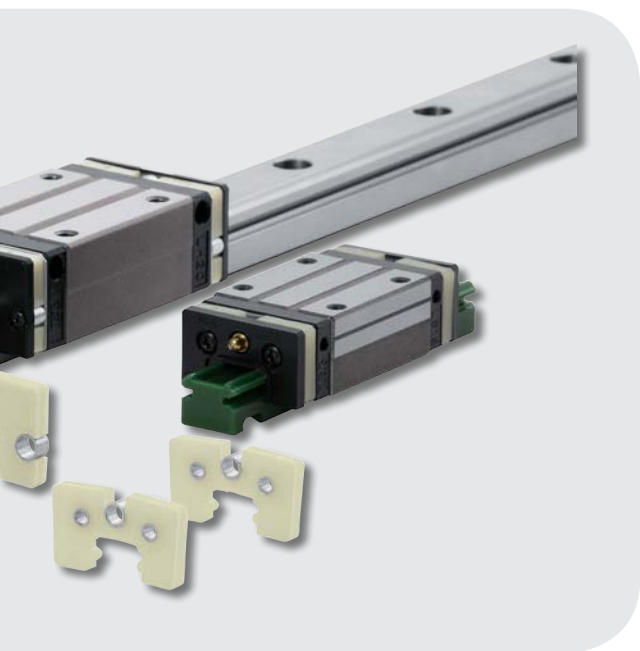

PRODUCED THROUGH STATE-OF-THE-ART TECHNOLOGY

Based on the LH/LS Series, which have achieved exceptional results in numerous application areas since their debut in 1989, the new NH/NS Series are created as the focal point of NSK's cumulated state-of-the-art design and manufacturing technologies.

LH/LS Series with reliability and performance

+

NSK's state-of-the-art design/manufacturing technologies

=

New series of standard linear guides:
the NH Series and NS Series

BALL GROOVE GEOMETRY CONTRIBUTING TO LONG LIFE

New ball groove geometry is introduced, which has been developed by utilizing NSK's state-of-the-art tribological and analytical technologies. Due to the optimized distribution of contact surface pressure, the rating life has dramatically increased. As compared with the LH/LS Series, the load rating capacity of the new series has increased 1.3 times, while the life span has increased two times*1.

*1: Representative values of each series.

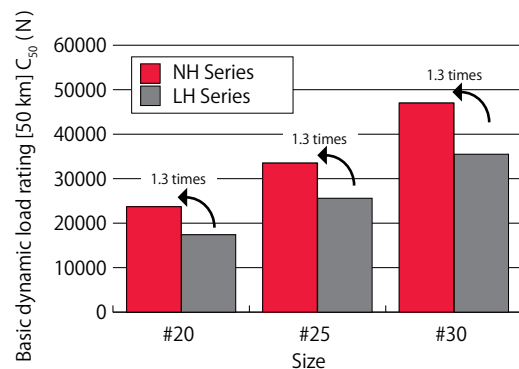

BALL CIRCULATING GROOVE WITH EXCELLENT HIGH-SPEED CAPABILITY

By re-examining the design for the ball circulation path, we have attained smoother ball circulation and a reduced noise level. The new NH/NS series are well suited for high-speed applications.

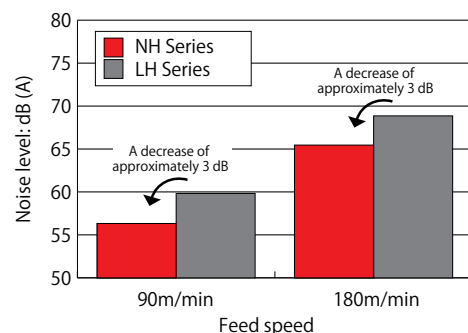

*Measurement results are obtained from the size #25 linear guide alone.
Microphone position: 500 mm above the top of the sample.
The noise level varies depending on the microphone position.

NH SERIES NOMENCLATURE

INTERCHANGEABLE TYPE NOMENCLATURE

The rails and slides may be purchased separately or as an assembly for NH Series.

Reference Part Number for Interchangeable Assembly (Ball Slide + Rail)

NH	20	3960	EM		2	PC	Z	K1		P	F	20
SERIES NAME	SIZE	RAIL LENGTH (MM)	SHAPE/ HEIGHT	MATERIAL/ SURFACE TREATMENT Blank: Standard carbon steel S: Stainless steel A: Carbon steel + Armoloy B: Stainless steel + Armoloy	NUMBER OF BALL SLIDES PER RAIL A number must always be placed in this field including the need for only one slider	ACCURACY PC: Interchangeable grade	PRELOAD/ CLEARANCE Z: Preload T: Clearance H: Medium preload	K1™ LUBRICATION SYSTEM Blank: No K1™ Lube Units K1: 1 K1™ Unit per side K2: 2 K1™ Units per side K3: 3 K1™ Units per side	SEAL OPTIONS Blank: 1 seal per slide H: HP seals; must also use K1™ in previous field D: Double standard seals	PROTECTOR PLATE Blank: No P: Protector per side	FRANKLIN, INDIANA PRODUCTION	G1 DIMENSION Distance from the end of the rail to the center of the first bolt-hole 20=20mm

LINEAR GUIDE SLIDE AND RAIL NOMENCLATURE

Part Number Example for Ball Slide Only

NAH	25	AN	S	Z	-K1
INTERCHANGEABLE BALL SLIDE TYPE	SIZE	SHAPE/HEIGHT AN: Square - Standard BN: Square - Long EM: Flanged (Tapped & Thru Hole) - Standard GM: Flanged (Tapped & Thru Hole) - Long	MATERIAL/ SURFACE TREATMENT Blank: Standard carbon steel S: Stainless steel A: Carbon steel + Armoloy B: Stainless steel + Armoloy	PRELOAD Blank: Clearance type Z: Preloaded type H: Medium preload	ACCESSORIES Blank: No special accessories K1: 1 K1™ Unit per side K2: 2 K1™ Units per side D: Double seals each side P: Protector plate each side H: HP seal

Reference Part Number for Rail Only

N1H	25	1200	Z	20
INTERCHANGEABLE RAIL TYPE SERIES	SIZE	RAIL LENGTH (MM)	PRELOAD Z: For all rails (non-butting) -01Z: Butting rail	G1 DIMENSION Distance from the end of the rail to the center of the first bolt-hole 20=20mm

Note: NSK recommends the purchase of rail caps for use in harsh or contaminated environments. Reference (NH Series Accessories, page 17) to determine part number. Plastic and brass caps available.

Only standard products have been identified in this catalog. For complete listing of NSK linear guide product offerings, refer to e3162.

NH SERIES ACCESSORIES

PROTECTOR PLATE AND DOUBLE SEAL

Travel length is reduced by the thickness of the end seal on the ball slide. Consider the value of V in the table below when calculating the travel length.

Protector Plate			Unit: mm
Linear Guide Model No.	Protector No. Plug End	Protector No. Grease Fitting End	Increased Thickness V_1
NH15	LH15PT-01	LH15PTC-01	2.7
NH20	LH20PT-01	LH20PTC-01	2.9
NH25	LH25PT-01	LH25PTC-01	3.2
NH30	LH30PT-01	LH30PTC-01	4.2
NH35	LH35PT-01	LH35PTC-01	4.2
NH45	LH45PT-01	LH45PTC-01	4.9
NH55	LH55PT-01	LH55PTC-01	4.9
NH65	LH65PT-01	LH65PTC-01	5.5

One of each PT and PTC is required to do one linear bearing.

Figure 2

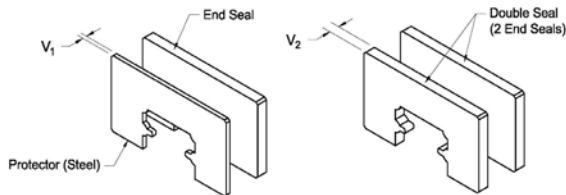

NOTE: V_1 includes the thickness of the screw head.

ADAPTERS

These parts connect piping to the tapped hole when the grease fitting is removed.

Figure 3

LF Type

For NH20, 25
NH30, 35

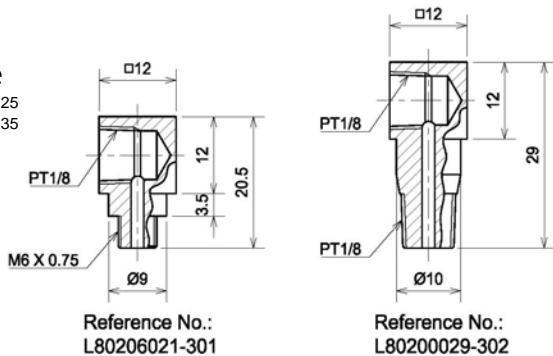

Reference No.:
L80206021-301

Reference No.:
L80200029-302

SF Type

For NH20, 25
NH30, 35

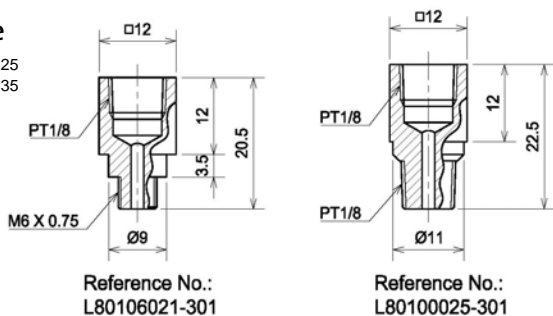

Reference No.:
L80106021-301

Reference No.:
L80100025-301

Double Seal			Unit: mm
Linear Guide Model No.	Double Seal No. Plug End	Double Seal No. Grease Fitting End	Increased Thickness V_2
NH15	LH15WS-01	LH15WSC-01	2.5
NH20	LH20WS-01	LH20WSC-01	2.5
NH25	LH25WS-01	LH25WSC-01	2.8
NH30	LH30WS-01	LH30WSC-01	3.6
NH35	LH35WS-01	LH35WSC-01	3.6
NH45	LH45WS-01	LH45WSC-01	4.3
NH55	LH55WS-01	LH55WSC-01	4.3
NH65	LH65WS-01	LH65WSC-01	4.9

One of each WS and WSC is required to do one linear bearing.

Figure 4

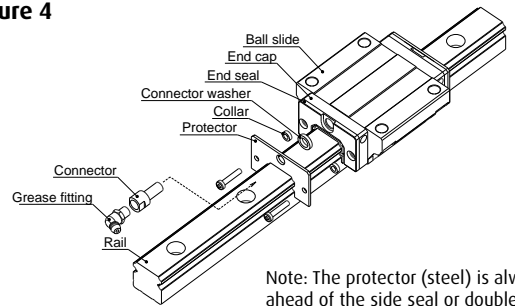

Note: The protector (steel) is always ahead of the side seal or double seal.

Plastic Cap for Rail Mounting Hole

Linear Guide Model No.	Rail Mounting Bolt Size	Cap. No. for Rail Mounting Hole
NH15	M4	L45800004-003
NH20	M5	L45800005-003
NH25	M6	L45800006-003
NH30	M8	L45800008-003
NH35	M8	L45800008-003
NH45	M12	L45800012-003
NH55	M14	L45800014-003
NH65	M16	L45800016-003

Brass Cap for Rail Mounting Hole

Linear Guide Model No.	Rail Mounting Bolt Size	Cap. No. for Rail Mounting Hole
NH20	M5	L45800005-004
NH25	M6	L45800006-004
NH30	M8	L45800008-004
NH35	M8	L45800008-004
NH45	M12	L45800012-004

NH SERIES

Front view of AN and BN types

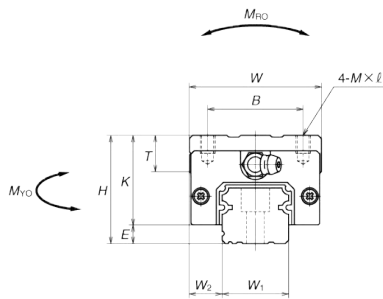

Side view of AN type

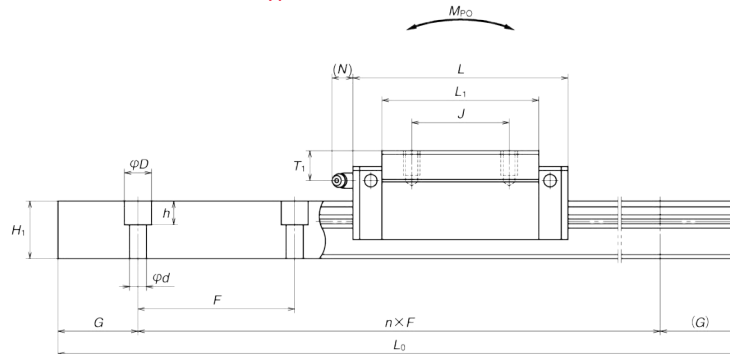

Side view of BN type

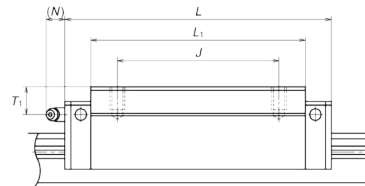

Model No.	Assembly			Ball slide									Rail			
	Height H	E	W_2	Width W	Length L	Mounting hole			L_1	K	T	Grease fitting			Width W_1	Height H_1
						B	J	M×Pitch× l				Hole size	T_1	N		
NH15AN NH15BN	28	4.6	9.5	34	55 74	26	26	M4×0.7×6	39 58	23.4	8	$\phi 3$	8.5	3.3	15	15
NH20AN NH20BN	30	5	12	44	69.8 91.8	32	36 50	M5×0.8×6	50 72	25	12	M6×0.75	5	11	20	18
NH25AN NH25BN	40	7	12.5	48	79 107	35	35 50	M6×1×9	58 86	33	12	M6×0.75	10	11	23	22
NH30AN NH30BN	45	9	16	60	85.6 124.6	40	40 60	M8×1.25×10	59 98	36	14	M6×0.75	10	11	28	26
NH35AN NH35BN	55	9.5	18	70	109 143	50	50 72	M8×1.25×12	80 114	45.5	15	M6×0.75	15	11	34	29
NH45AN NH45BN	70	14	20.5	86	139 171	60	60 80	M10×1.5×17	105 137	56	17	Rc1/8	20	13	45	38
NH55AN NH55BN	80	15	23.5	100	163 201	75	75 95	M12×1.75×18	126 164	65	18	Rc1/8	21	13	53	44
NH65AN NH65BN	90	16	31.5	126	193 253	76	70 120	M16×2×20	147 207	74	23	Rc1/8	19	13	63	53

Notes: 1) External appearance of stainless steel ball slides differs from those of carbon steel ball slides.

Rail of interchangeable type

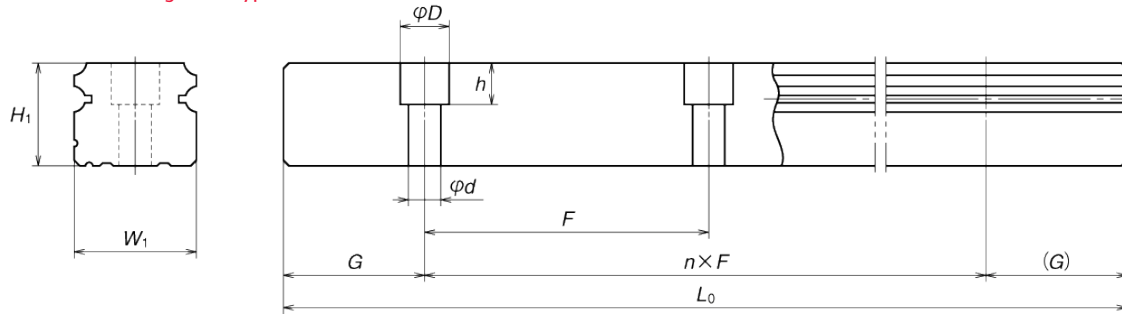

Unit: mm

Rail			Basic load rating								Weight	
Pitch F	Mounting bolt hole d×D×h	Max. length L _{omax} () for stainless	Dynamic		Static C ₀ (N)	M _{RO}	Static moment (N·m)				Ball slide (kg)	Rail (kg/m)
			[50km] C ₅₀ (N)	[100km] C ₁₀₀ (N)			M _{PO}		M _{VO}			
							(One slide)	(Two slides)	(One slide)	(Two slides)		
60	4.5×7.5×5.3	2 980 (1 800)	14 200	11 300	20 700	108	94.5	575	79.5	480	0.18	1.6
			18 100	14 400	32 000	166	216	1 150	181	965	0.26	
60	6×9.5×8.5	3 960 (3 500)	23 700	18 800	32 500	219	185	1 140	155	955	0.33	2.6
			30 000	24 000	50 500	340	420	2 230	355	1 870	0.48	
60	7×11×9	3 960 (3 500)	33 500	26 800	46 000	360	320	1 840	267	1 540	0.55	3.6
			45 500	36 500	71 000	555	725	3 700	610	3 100	0.82	
80	9×14×12	4 000 (3 500)	41 000	32 500	51 500	490	350	2 290	292	1 920	0.77	5.2
			61 000	48 500	91 500	870	1 030	5 600	865	4 700	1.3	
80	9×14×12	4 000	62 500	49 500	80 500	950	755	4 500	630	3 800	1.5	7.2
			81 000	64 500	117 000	1 380	1 530	8 350	1 280	7 000	2.1	
105	14×20×17	3 990	107 000	84 500	140 000	2 140	1 740	9 750	1 460	8 150	3.0	12.3
			131 000	104 000	187 000	2 860	3 000	15 600	2 520	13 100	3.9	
120	16×23×20	3 960	158 000	125 000	198 000	3 600	3 000	16 300	2 510	13 700	4.7	16.9
			193 000	153 000	264 000	4 850	5 150	26 300	4 350	22 100	6.1	
150	18×26×22	3 900	239 000	190 000	281 000	6 150	4 950	27 900	4 150	23 400	7.7	24.3
			310 000	246 000	410 000	8 950	10 100	51 500	8 450	43 500	10.8	

- 2) The basic load rating comply with the ISO standard. (ISO14728-1 and ISO14728-2)
C₅₀: the basic dynamic load rating for 50 km rating fatigue life, C₁₀₀: the basic dynamic load rating for 100 km rating fatigue life
The basic static load rating shows static permissible load.
3) Need to specify G dimension on every order. Please contact your NSK representative with questions.

NH SERIES

Front view of EM and GM types

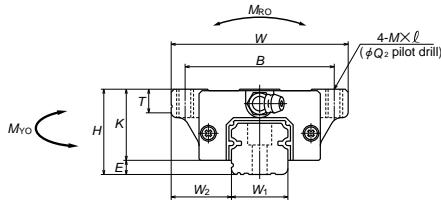

Side view of EM type

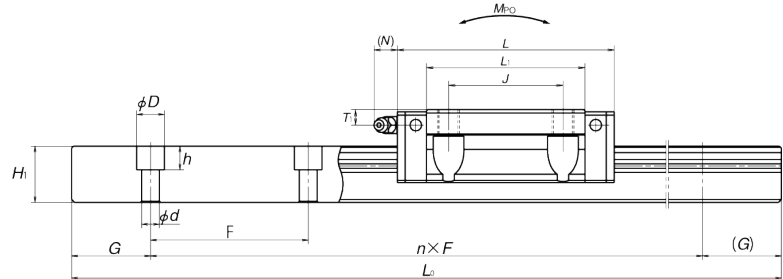

Side view of GM type

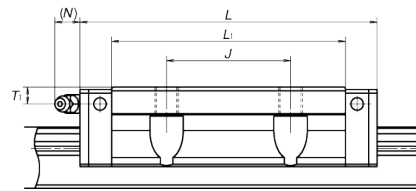

Model No.	Assembly			Ball slide										Rail			
	Height H	E	W ₂	Width W	Length L	Mounting hole				L ₁	K	T	Grease fitting			Width W ₁	Height H ₁
						B	J	M×Pitch×ℓ	Q ₂				Hole size	T ₁	N		
NH15EM NH15GM	24	4.6	16	47	55 74	38	30	M5×0.8×7	4.4	39 58	19.4	8	∅3	4.5	3.3	15	15
NH20EM NH20GM	30	5	21.5	63	69.8 91.8	53	40	M6×1×9.5	5.3	50 72	25	10	M6×0.75	5	11	20	18
NH25EM NH25GM	36	7	23.5	70	79 107	57	45	M8×1.25×10 (M8×1.25×11.5)	6.8	58 86	29	11 (12)	M6×0.75	6	11	23	22
NH30EM NH30GM	42	9	31	90	98.6 124.6	72	52	M10×1.5×12 (M10×1.5×14.5)	8.6	72 98	33	11 (15)	M6×0.75	7	11	28	26
NH35EM NH35GM	48	9.5	33	100	109 143	82	62	M10×1.5×13	8.6	80 114	38.5	12	M6×0.75	8	11	34	29
NH45EM NH45GM	60	14	37.5	120	139 171	100	80	M12×1.75×15	10.5	105 137	46	13	Rc1/8	10	13	45	38
NH55EM NH55GM	70	15	43.5	140	163 201	116	95	M14×2×18	12.5	126 164	55	15	Rc1/8	11	13	53	44
NH65EM NH65GM	90	16	53.5	170	193 253	142	110	M16×2×24	14.6	147 207	74	23	Rc1/8	19	13	63	53

Notes: 1) Parenthesized dimensions are for items made of stainless steel.
2) External appearance of stainless steel ball slides differs from those of carbon steel ball slides.

Rail of interchangeable type

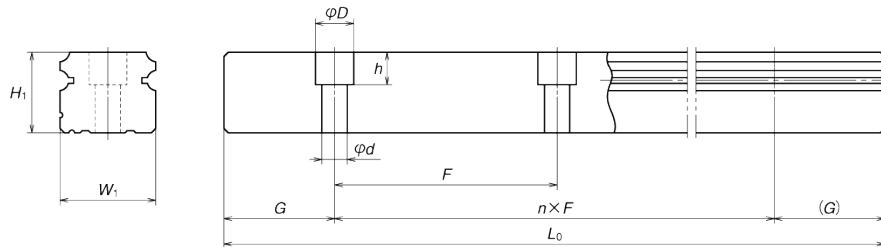

Unit: mm

Rail			Basic load rating								Weight	
Pitch F	Mounting bolt hole d×D×h	Max. length L _{0max} () for stainless	3)Dynamic		Static	M _{RO}	Static moment (N-m)				Ball slide (kg)	Rail (kg/m)
			[50km] C ₅₀ (N)	[100km] C ₁₀₀ (N)	C ₀ (N)		M _{P0}		M _{V0}			
							(One slide)	(Two slides)	(One slide)	(Two slides)		
60	4.5×7.5×5.3	2 980 (1 800)	14 200	11 300	20 700	108	94.5	575	79.5	480	0.17	1.6
			18 100	14 400	32 000	166	216	1 150	181	965	0.25	
60	6×9.5×8.5	3 960 (3 500)	23 700	18 800	32 500	219	185	1 140	155	955	0.45	2.6
			30 000	24 000	50 500	340	420	2 230	355	1 870	0.65	
60	7×11×9	3 960 (3 500)	33 500	26 800	46 000	360	320	1 840	267	1 540	0.63	3.6
			45 500	36 500	71 000	555	725	3 700	610	3 100	0.93	
80	9×14×12	4 000 (3 500)	47 000	37 500	63 000	600	505	3 150	425	2 650	1.2	5.2
			61 000	48 500	91 500	870	1 030	5 600	865	4 700	1.6	
80	9×14×12	4 000	62 500	49 500	80 500	950	755	4 500	630	3 800	1.7	7.2
			81 000	64 500	117 000	1 380	1 530	8 350	1 280	7 000	2.4	
105	14×20×17	3 990	107 000	84 500	140 000	2 140	1 740	9 750	1 460	8 150	3.0	12.3
			131 000	104 000	187 000	2 860	3 000	15 600	2 520	13 100	3.9	
120	16×23×20	3 960	158 000	125 000	198 000	3 600	3 000	16 300	2 510	13 700	5.0	16.9
			193 000	153 000	264 000	4 850	5 150	26 300	4 350	22 100	6.5	
150	18×26×22	3 900	239 000	190 000	281 000	6 150	4 950	27 900	4 150	23 400	10.0	24.3
			310 000	246 000	410 000	8 950	10 100	51 500	8 450	43 500	14.1	

3) The basic load rating comply with the ISO standard. (ISO14728-1 and ISO14728-2)
C₅₀: the basic dynamic load rating for 50 km rating fatigue life, C₁₀₀: the basic dynamic load rating for 100 km rating fatigue life
The basic static load rating shows static permissible load.

4) Need to specify G dimension on every order. Please contact your NSK representative with questions.

NS SERIES NOMENCLATURE

INTERCHANGEABLE TYPE NOMENCLATURE

The rails and slides may be purchased separately or as an assembly for NS Series.

Reference Part Number for Interchangeable Assembly (Ball Slide + Rail)

NS	20	3960	EM		2	PC	Z	K1		P	F	20
SERIES NAME	SIZE	RAIL LENGTH (MM)	SHAPE/ HEIGHT	MATERIAL/ SURFACE TREATMENT Blank: Standard carbon steel S: Stainless steel A: Carbon steel + Armoloy B: Stainless steel + Armoloy	NUMBER OF BALL SLIDES PER RAIL A number must always be placed in this field including the need for only one slider	ACCURACY PC: Interchangeable grade	PRELOAD/ CLEARANCE Z: Preload T: Clearance	K1™ LUBRICATION SYSTEM Blank: No K1™ Lube Units K1: 1 K1™ Unit per side K2: 2 K1™ Units per side K3: 3 K1™ Units per side	SEAL OPTIONS Blank: 1 seal per slide H: HP seals; must also use K1™ in previous field D: Double standard seals	PROTECTOR PLATE Blank: No Protector P: 1 protector per side	FRANKLIN, INDIANA PRODUCTION	G1 DIMENSION Distance from the end of the rail to the center of the first bolt-hole 20=20mm

LINEAR GUIDE SLIDE AND RAIL NOMENCLATURE

Part Number Example for Ball Slide Only

NAS	25	AL	S	Z	-K1
INTERCHANGEABLE BALL SLIDE TYPE	SIZE	SHAPE/HEIGHT AL: Square (4 Tapped Holes) - High Load CL: Square (2 Tapped Holes) - Medium Load JM: Flanged (2 Tapped Holes) - Medium Load EM: Flanged (4 Tapped Holes) - High Load	MATERIAL/ SURFACE TREATMENT S: Stainless steel D: Carbon steel fluoride coating A: Carbon steel + Armoloy B: Stainless steel + Armoloy	PRELOAD Blank: Clearance type Z: Preloaded type	ACCESSORIES Blank: No special accessories K1: 1 K1™ Unit per side K2: 2 K1™ Units per side D: Double seals each side P: Protector plate each side

Reference Part Number for Rail Only

N1S	15	2920	S	T	Z	20
INTERCHANGEABLE RAIL TYPE SERIES	SIZE	RAIL LENGTH (MM)	MATERIAL/ SURFACE TREATMENT Blank: Standard carbon steel S: Stainless steel A: Carbon steel + Armoloy B: Stainless steel + Armoloy	FOR N1S15 RAIL SIZE ONLY: T: Counterbore hole for M3 Counterbore hole for M4	PRELOAD Blank: Clearance type Z: For all rails (non-butting) -0T: Butting rail	G1 DIMENSION Distance from the end of the rail to the center of the first bolt-hole 20=20mm

Note: NSK recommends the purchase of rail caps for use in harsh or contaminated environments. Reference (NS Series Accessories, page 23) to determine part number. Plastic and brass caps available.

Only standard products have been identified in this catalog. For complete listing of NSK linear guide product offerings, refer to e3162.

NS SERIES ACCESSORIES

PROTECTOR PLATE AND DOUBLE SEAL

Travel length is reduced by the thickness of the end seal on the ball slide. Consider the value of V in the table below when calculating the travel length.

Protector Plate			Unit: mm
Linear Guide Model No.	Protector No. Plug End	Protector No. Grease Fitting End	Increased Thickness V_1
NS15	LS15PT-01	LS15PTC-01	3.0
NS20	LS20PT-01	LS20PTC-01	2.7
NS25	LS25PT-01	LS25PTC-01	3.2
NS30	LS30PT-01	LS30PTC-01	4.2
NS35	LS35PT-01	LS35PTC-01	4.2

One of each PT and PTC is required to do one linear bearing.

Figure 5

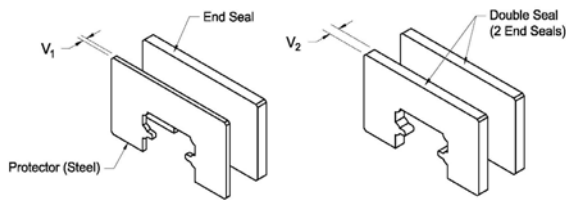

NOTE: V_1 includes the thickness of the screw head.

ADAPTERS

These parts connect piping to the tapped hole when the grease fitting is removed.

Figure 6

LF Type

For NS20, 25
NS30, 35

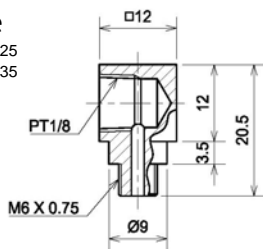

Reference No.:
L80206021-301

SF Type

For NS20, 25
NS30, 35

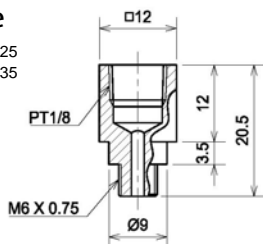

Reference No.:
L80106021-301

Double Seal			Unit: mm
Linear Guide Model No.	Double Seal No. Plug End	Double Seal No. Grease Fitting End	Increased Thickness V_2
NS15	LS15WS-01	LS15WSC-01	2.8
NS20	LS20WS-01	LS20WSC-01	2.5
NS25	LS25WS-01	LS25WSC-01	2.8
NS30	LS30WS-01	LS30WSC-01	3.6
NS35	LS35WS-01	LS35WSC-01	3.6

One of each WS and WSC is required to do one linear bearing.

Figure 7

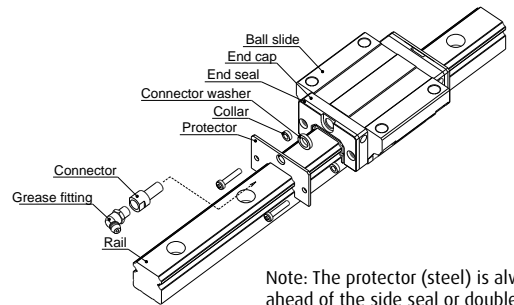

Note: The protector (steel) is always ahead of the side seal or double seal.

Plastic Cap for Rail Mounting Hole

Linear Guide Model No.	Rail Mounting Bolt Size	Cap. No. for Rail Mounting Hole
NS15	M3	L45800003-003
NS20	M5	L45800005-003
NS25	M6	L45800006-003
NS30	M6	L45800006-003
NS35	M8	L45800008-003

Brass Cap for Rail Mounting Hole

Linear Guide Model No.	Rail Mounting Bolt Size	Cap. No. for Rail Mounting Hole
NS20	M5	L45800005-004
NS25	M6	L45800006-004
NS30	M6	L45800006-004
NS35	M8	L45800008-004

NS SERIES

Front view of AL and CL types

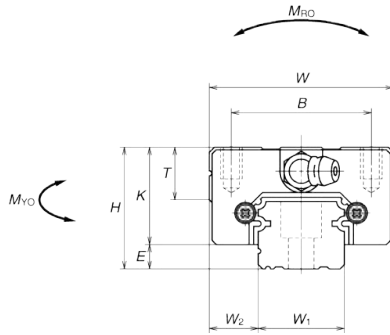

Side view of AL type

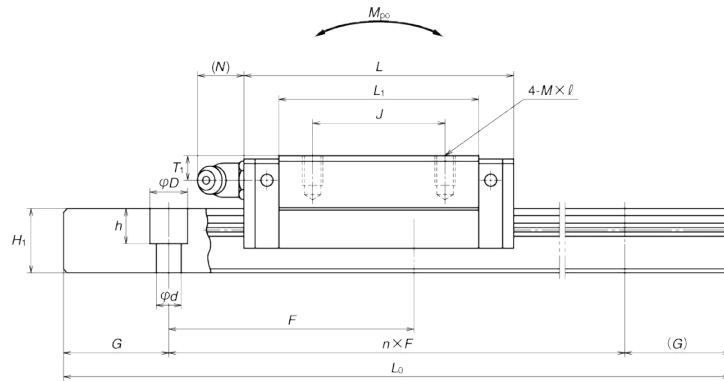

Side view of CL type

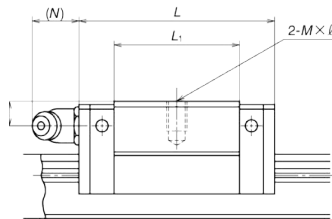

Model No.	Assembly			Ball slide											Rail			
	Height			Width	Length	Mounting hole					L ₁	K	T	Grease fitting			Width	Height
	H	E	W ₂			B	J	M×Pitch×ℓ	Hole size	T ₁				N	W ₁	H ₁		
NS15CL	24	4.6	9.5	34	40.4	26	—	M4×0.7×6	23.6	19.4	10	∅3	6	3	15	12.5		
NS15AL					56.8		26		40									
NS20CL	28	6	11	42	47.2	32	—	M5×0.8×7	30	22	12	M6×0.75	5.5	11	20	15.5		
NS20AL					65.2		32		48									
NS25CL	33	7	12.5	48	59.6	35	—	M6×1×9	38	26	12	M6×0.75	7	11	23	18		
NS25AL					81.6		35		60									
NS30CL	42	9	16	60	67.4	40	—	M8×1.25×12	42	33	13	M6×0.75	8	11	28	23		
NS30AL					96.4		40		71									
NS35CL	48	10.5	18	70	77	50	—	M8×1.25×12	49	37.5	14	M6×0.75	8.5	11	34	27.5		
NS35AL					108		50		80									

Notes: 1) External appearance of stainless steel ball slides differs from those of carbon steel ball slides.

2) The basic load rating comply with the ISO standard. (ISO14728-1 and ISO14728-2)

C₅₀: the basic dynamic load rating for 50 km rating fatigue life, C₁₀₀: the basic dynamic load rating for 100 km rating fatigue life

Rail of interchangeable type

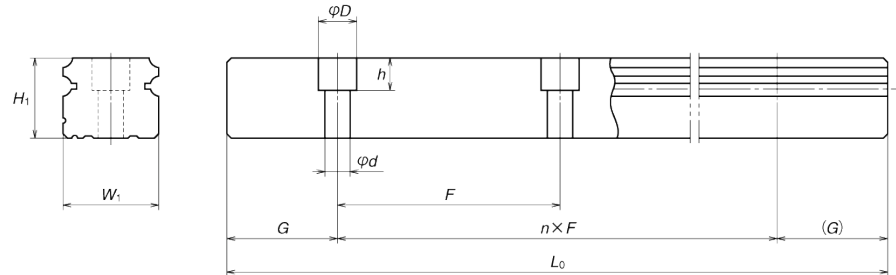

Unit: mm

Rail			Basic load rating								Weight	
Pitch F	Mounting bolt hole d×D×h	Max. length L _{0max} () for stainless	2)Dynamic		Static	M _{RO}	Static moment (N·m)				Ball slide (kg)	Rail (kg/m)
			[50km] C ₅₀ (N)	[100km] C ₁₀₀ (N)	C ₀ (N)		M _{PO}		M _{YO}			
							(One slide)	(Two slides)	(One slide)	(Two slides)		
60	*3.5×6×4.5	2 920	7 250	5 750	9 100	45.5	24.5	196	20.5	165	0.14	1.4
	4.5×7.5×5.3	(1 700)	11 200	8 850	16 900	84.5	77	470	64.5	395	0.20	
60	6×9.5×8.5	3 960	10 600	8 400	13 400	91.5	46.5	330	39	279	0.19	2.3
		(3 500)	15 600	12 400	23 500	160	133	755	111	630	0.28	
60	7×11×9	3 960	17 700	14 000	20 800	164	91	655	76	550	0.34	3.1
		(3 500)	26 100	20 700	36 500	286	258	1 470	217	1 230	0.51	
80	7×11×9	4 000	24 700	19 600	29 600	282	139	1 080	116	905	0.58	4.8
		(3 500)	38 000	30 000	55 000	520	435	2 650	365	2 220	0.85	
80	9×14×12	4 000	34 500	27 300	40 000	465	220	1 670	185	1 400	0.86	7.0
		(3 500)	52 500	42 000	74 500	865	695	4 000	580	3 350	1.3	

3) Need to specify G dimension on every order. Please contact your NSK representative with questions.

*) Standard rail mounting bolt hole for NS15 is specified as hole for M3 (3.5 x 6 x 4.5).

Please contact NSK to request a different hole for M4 (4.5 x 7.5 x 5.3).

NS SERIES

Front view of EM and JM types

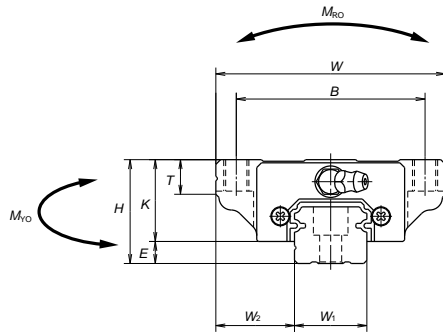

Side view of EM type

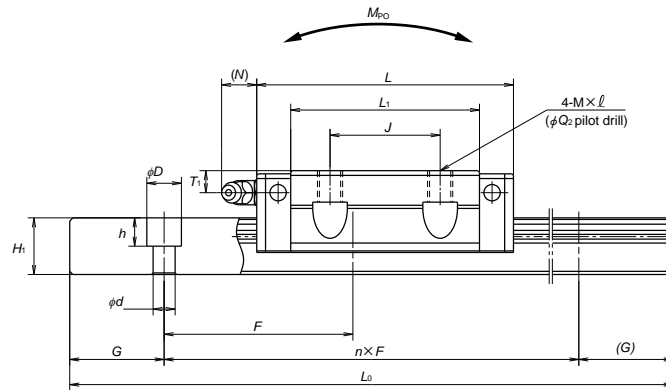

Side view of JM type

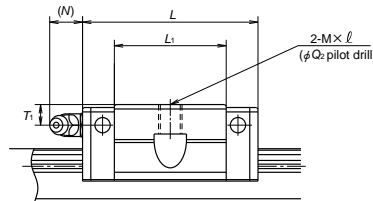

Model No.	Assembly			Ball slide										Rail			
	Height	E	W_2	Width	Length	Mounting hole				L_1	K	T	Grease fitting			Width	Height
						B	J	$M \times \text{Pitch} \times l$	Q_2				Hole size	T_1	N		
NS15JM NS15EM	24	4.6	18.5	52	40.4 56.8	41	— 26	M5×0.8×7	4.4	23.6 40	19.4	8	$\phi 3$	6	3	15	12.5
NS20JM NS20EM	28	6	19.5	59	47.2 65.2	49	— 32	M6×1×9 (M6×1×9.5)	5.3	30 48	22	10	M6×0.75	5.5	11	20	15.5
NS25JM NS25EM	33	7	25	73	59.6 81.6	60	— 35	M8×1.25×10 (M8×1.25×11.5)	6.8	38 60	26	11 (12)	M6×0.75	7	11	23	18.0
NS30JM NS30EM	42	9	31	90	67.4 96.4	72	— 40	M10×1.5×12 (M10×1.5×14.5)	8.6	42 71	33	11 (15)	M6×0.75	8	11	28	23.0
NS35JM NS35EM	48	10.5	33	100	77 108	82	— 50	M10×1.5×13 (M10×1.5×14.5)	8.6	49 80	37.5	12 (15)	M6×0.75	8.5	11	34	27.5

Notes: 1) External appearance of stainless steel ball slides differs from those of carbon steel ball slides.
2) Parenthesized dimensions are for items made of stainless steel.

Rail of interchangeable type

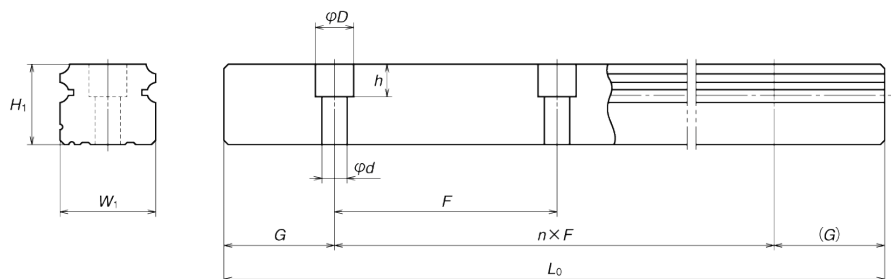

Unit: mm

Rail			Basic load rating								Weight	
Pitch F	Mounting bolt hole d×D×h	Max. length L _{0max} () for stainless	3)Dynamic		Static	Static moment (N·m)				Ball slide (kg)	Rail (kg/m)	
			[50km] C ₅₀ (N)	[100km] C ₁₀₀ (N)	C ₀ (N)	M _{RO}	M _{PO}		M _{YO}			
							(One slide)	(Two slides)	(One slide)	(Two slides)		
60	*3.5×6×4.5	2 920	7 250	5 750	9 100	45.5	24.5	196	20.5	165	0.17	1.4
	4.5×7.5×5.3	(1 700)	11 200	8 850	16 900	84.5	77	470	64.5	395	0.26	
60	6×9.5×8.5	3 960	10 600	8 400	13 400	91.5	46.5	330	39	279	0.24	2.3
		(3 500)	15 600	12 400	23 500	160	133	755	111	630	0.35	
60	7×11×9	3 960	17 700	14 000	20 800	164	91	655	76	550	0.44	3.1
		(3 500)	26 100	20 700	36 500	286	258	1 470	217	1 230	0.66	
80	7×11×9	4 000	24 700	19 600	29 600	282	139	1 080	116	905	0.76	4.8
		(3 500)	38 000	30 000	55 000	520	435	2 650	365	2 220	1.2	
80	9×14×12	4 000	34 500	27 300	40 000	465	220	1 670	185	1 400	1.2	7.0
		(3 500)	52 500	42 000	74 500	865	695	4 000	580	3 350	1.7	

3) The basic load rating comply with the ISO standard. (ISO14728-1 and ISO14728-2)

C₅₀: the basic dynamic load rating for 50 km rating fatigue life, C₁₀₀: the basic dynamic load rating for 100 km rating fatigue life

The basic static load rating shows static permissible load.

4) Need to specify G dimension on every order. Please contact your NSK representative with questions.

*) Standard rail mounting bolt hole for NS15 is specified as hole for M3 (3.5 x 6 x 4.5).

Please contact NSK to request a different hole for M4 (4.5 x 7.5 x 5.3).

LW SERIES



FEATURES:

- High moment rigidity achieved by wide, low profile rail.
- Best suited for single rail linear guide systems.
- Offset Gothic arch groove minimizes friction.
- Provides high resistance against impact loads.
- Increased load carrying capacity in vertical direction due to 50 degree contact angle between ball and ball groove.
- Optional K1™ Lubrication Units provide maintenance-free operation.
- Inventory available in various sizes and models of ball slide to facilitate fast delivery.

LW SERIES NONEMCLATURE AND ACCESSORIES

INTERCHANGEABLE TYPE NOMENCLATURE

The rails and slides may be purchased separately or as an assembly for LW Series.

Reference Part Number for Interchangeable Assembly (Ball Slide + Rail)

LW	27	3960	EL		2	PC	Z	K1		P	F	20
SERIES NAME	SIZE	RAIL LENGTH (MM)	SHAPE/ HEIGHT	MATERIAL/ SURFACE TREATMENT	NUMBER OF BALL SLIDES PER RAIL	ACCURACY PC: Interchangeable grade	PRELOAD/ CLEARANCE Z: Preload T: Clearance	K1™ LUBRICATION SYSTEM Blank: No K1™ Lube Units K1: 1 K1™ Unit per side K2: 2 K1™ Units per side K3: 3 K1™ Units per side	SEAL OPTIONS Blank: 1 seal per slide HP seals; must also use K1™ in previous field D: Double standard seals	SCRAPERS Blank: No scrapers per side P: 1 scraper per side	FRANKLIN, INDIANA PRODUCTION	G1 DIMENSION Distance from the end of the rail to the center of the first bolt-hole 20=20mm
				Blank: Standard carbon steel S: Stainless steel A: Carbon steel + Armoloy B: Stainless steel + Armoloy	A number must always be placed in this field including the need for only one slider							

LINEAR GUIDE SLIDE AND RAIL NOMENCLATURE

Part Number Example for Ball Slide Only

LAW	27	EL	K1	Z
INTERCHANGEABLE BALL SLIDE TYPE	SIZE	SHAPE/HEIGHT EL: Flanged (Tapped Hole)	ACCESSORIES Blank: No special accessories K1: 1 K1™ Unit per side K2: 2 K1™ Units per side K3: 3 K1™ Units per side P: 1 scraper per side	PRELOAD Blank: Clearance Z: Light Preload

Reference Part Number for Rail Only

L1W	27	0820	Z	20
RAIL TYPE	SIZE	RAIL LENGTH (MM)	PRELOAD Blank: Clearance Z: For all units -01Z: Butting rail	G1 DIMENSION Distance from the end of the rail to the center of the first bolt-hole 20=20mm

Note: NSK recommends the purchase of rail caps for use in harsh or contaminated environments. Reference (LW Series Accessories, below) to determine part number. Plastic and brass caps available.

ACCESSORIES

Plastic Cap for Rail Mounting Hole

Linear Guide Model No.	Rail Mounting Bolt Size	Cap. No. for Rail Mounting Hole
LW17	M4	L45800004-003
LW21	M4	L45800004-003
LW27	M4	L45800004-003
LW35	M6	L45800006-003
LW50	M8	L45800008-003

Brass Cap for Rail Mounting Hole

Linear Guide Model No.	Rail Mounting Bolt Size	Cap. No. for Rail Mounting Hole
LW17	M4	L45800004-004
LW21	M4	L45800004-004
LW27	M4	L45800004-004
LW35	M6	L45800006-004
LW50	M8	L45800008-004

Only standard products have been identified in this catalog. For complete listing of NSK linear guide product offerings, refer to e3162.

LW SERIES

Front view of EL type

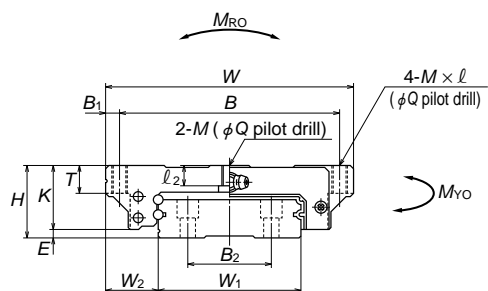

Side view of EL type

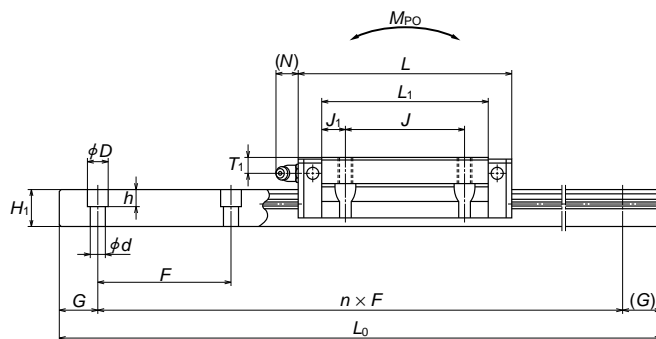

Model No.	Assembly					Ball Slide											Grease Fitting		
	Height H	E	W ₂	Width W	Length L	Mounting Hole			l ₂	Q	B ₁	L ₁	J ₁	K	T	Hole size	T ₁	N	
						B	J	M x pitch x l											
LW17EL	17	2.5	13.5	60	51.4	53	26	M4 x 0.7 x 6	3.5	3.3	3.5	35	4.5	14.5	6	φ3	4	3	
LW21EL	21	3	15.5	68	58.8	60	29	M5 x 0.8 x 8	3.7	4.4	4	41	6	18	8	M6 x 0.75	4.5	11	
LW27EL	27	4	19	80	74	70	40	M6 x 1 x 10	6	5.3	5	56	8	23	10	M6 x 0.75	6	11	
LW35EL	35	4	25.5	120	108	107	60	M8 x 1.25 x 14	9	6.8	6.5	84	12	31	14	M6 x 0.75	8	11	
LW50EL	50	4.5	36	162	140.6	144	80	M10 x 1.5 x 18	14	8.6	9	108	14	45.5	18	Rc1\8	14	14	

Rail of EL type

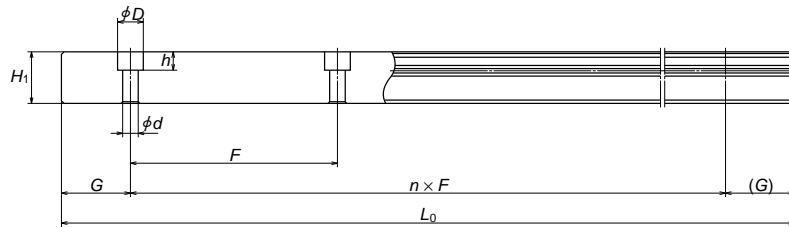
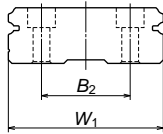

Unit: mm

Rail						Basic Load Rating								Weight	
Width W_1	Height H_1	B_2	Pitch F	Mounting Bolt Hole	Max Length L_{max}	²⁾ Dynamic	Static	Static Moment				Ball slide (kg)	Rail (kg/m)		
						C_{50}	C_0	M_{10}	M_{p0}		M_{y0}				
				$d \times D \times h$	¹⁾ () for Stainless (N)	(N)	One Slide		Two Slides	One Slide	Two Slides				
33	8.7	18	40	4.5 x 7.5 x 5.3	1000	5,600	11,300	135	44	288	37	242	0.2	2.1	
37	10.5	22	50	4.5 x 7.5 x 5.3	1600	6,450	13,900	185	65.5	400	55	335	0.3	2.9	
42	15.0	24	60	4.5 x 7.5 x 5.3	2000	12,800	26,900	400	171	970	143	815	0.5	4.7	
69	19.0	40	80	7 x 11 x 9	2000	33,000	66,500	1690	645	3550	545	2990	1.5	9.6	
90	24.0	60	80	9 x 14 x 12	2000	61,500	117,000	3900	1530	8200	1280	6900	4.0	15.8	

1) LW Series not available in stainless.

2) The basic load rating comply with the ISO standard. (ISO14728-1 and ISO14728-2)

C_{50} : the basic dynamic load rating for 50 km rating fatigue life, C_{100} : the basic dynamic load rating for 100 km rating fatigue life
The basic static load rating shows static permissible load.

3) Need to specify G dimension on every order. Please contact your NSK representative with questions.

PU/PE SERIES

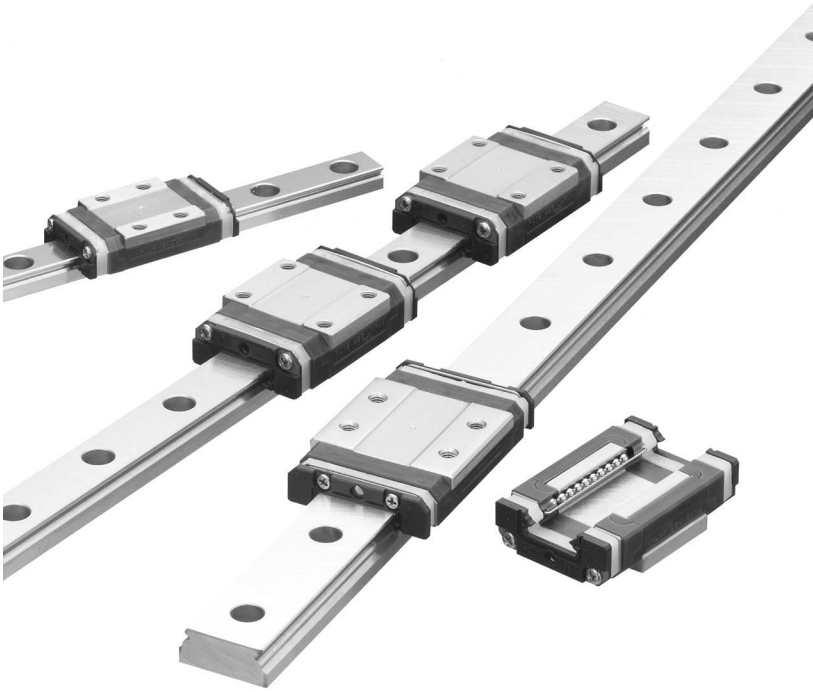

FEATURES:

- Lightweight design.
- Ball slide recirculation area is formulated of a resin material and is 20% lighter weight than conventional miniature models.
- Smooth travel with reduced noise.
- Compact space between side of rails and inner walls of ball slide prevents entrance of foreign contaminants.
- Stainless steel material provides excellent corrosion resistance.
- Ball slide features retained steel balls for easy handling.
- Equipped with K1™ Lubrication Units to extend product life and provide maintenance-free operation.
- Inventory available in various sizes and models of ball slide to facilitate fast delivery.

DIFFERENCE OF PE SERIES:

- PE series are a miniature wide rail type.
- Ideal for single rail use because of its load carry capacity against high moment loads.

PU/PE SERIES NOMENCLATURE AND ACCESSORIES

INTERCHANGEABLE TYPE NOMENCLATURE

The rails and slides may be purchased separately or as an assembly for PU/PE Series.

Reference Part Number for Interchangeable Assembly (Ball Slide + Rail)

PU	15	1000	AL	S	2	PC	T	K1	F	20
SERIES NAME	SIZE	RAIL LENGTH (MM)	SHAPE/HEIGHT	MATERIAL/SURFACE TREATMENT S: Stainless steel	NUMBER OF BALL SLIDES PER RAIL A number must always be placed in this field including the need for only one slider	ACCURACY PC: Interchangeable grade	PRELOAD/CLEARANCE T: Clearance	K1™ LUBRICATION SYSTEM Blank: No K1™ Lube Units K1: 1 K1™ Unit per side	FRANKLIN, INDIANA PRODUCTION	G1 DIMENSION Distance from the end of the rail to the center of the first bolt-hole 20=20mm

LINEAR GUIDE SLIDE AND RAIL NOMENCLATURE

Part Number Example for Ball Slide Only

PA	U	15	AL	S	K
SINGLE BALL SLIDE CODE	SERIES NAME U: PU E: PE	SIZE	SHAPE/HEIGHT	MATERIAL CODE S: Stainless steel	OPTION CODE Blank: No options K: With NSK K1™

Reference Part Number for Rail Only

P1	U	15	0470	S	Z	20
INTERCHANGEABLE SERIES RAIL TYPE	SERIES NAME U: PU E: PE	SIZE	RAIL LENGTH (MM)	MATERIAL CODE S: Stainless Steel	PRELOAD Z: For all Non-butting -01Z: Butting rail	G1 DIMENSION Distance from the end of the rail to the center of the first bolt-hole 20=20mm

Note: NSK recommends the purchase of rail caps for use in harsh or contaminated environments. Reference (PU/PE Series Accessories, below) to determine part number.

ACCESSORIES

Plastic Cap for Rail Mounting Hole

Linear Guide Model No.	Rail Mounting Bolt Size	Cap. No. for Rail Mounting Hole
PU09, PU12, PU15, PE09	M3	L45800003-003

Only standard products have been identified in this catalog. For complete listing of NSK linear guide product offerings, refer to e3162.

PU/PE SERIES

Front view of PU type

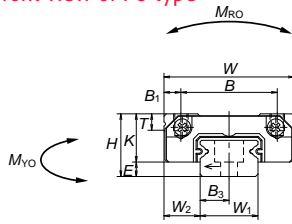

PU05, 07, 09, 12

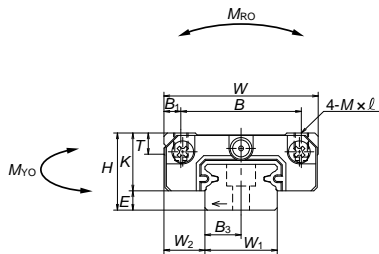

PU15

Side view of PU type

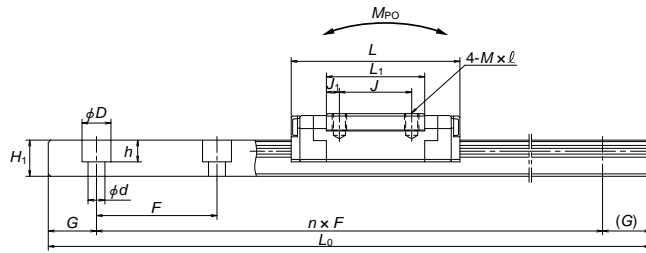

PU07, 09, 12

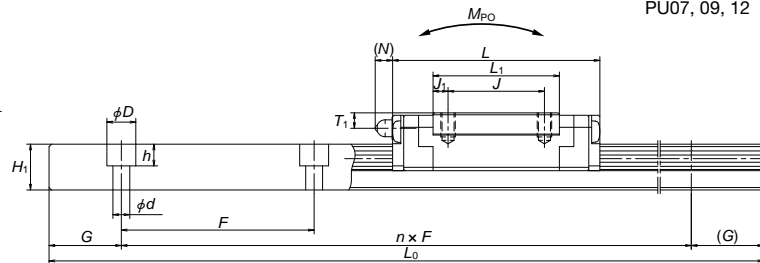

PU15

Rail of PU type

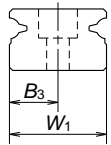

PU09,12,15

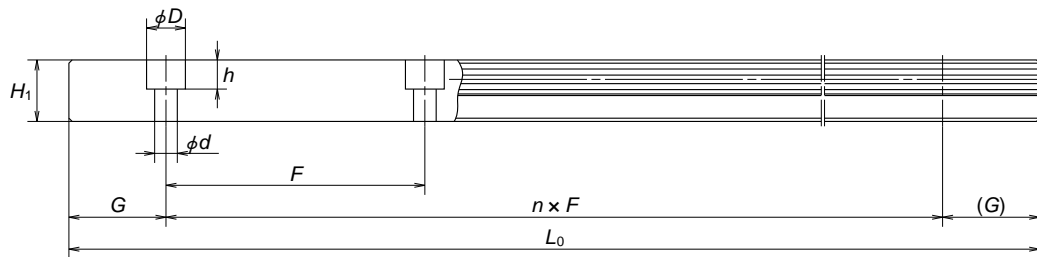

Model No.	Assembly					Ball Slide											
	Height H	E	W ₂	Width W	Length L	Mounting Hole			B ₁	L ₁	J ₁	K	T	Grease Fitting			
						B	J	M x pitch x l						Hole size	T ₁	N	
PU09TR	10	2.2	5.5	20	30.0	10			19.6	4.8							
PU09UR					41.0	16	M3 x 0.5 x 3	2.5	30.6	7.3							
PE09TR	12	4	6.0	30	39.8	21	12		4.5	26.6	7.3						
PE09UR					51.2	23	24	M3 x 0.5 x 3	3.5	38.0	7.0	8.0	2.8	ø2	2.3		
PU12TR	13	3	7.5	27	35.0	15			20.4	2.7							
PU12UR					48.7	20		M3 x 0.5 x 3.5	3.5	34.1	7.0	10.0	3.4				
PE12AR	14	4	8.0	40	45.0	28	15		31.0	8.0							
PE12BR					60.0	28	28	M3 x 0.5 x 4	6.0	46.0	9.0	10.0	3.2	ø2.5	2.7		
PU15AL	16	4	8.5	32	43.0	25	20		26.2	3.1							
PU15BL					61.0	25		M3 x 0.5 x 5	3.5	44.2	9.6	12.0	4.4	ø3	3.2	(3.6)	
PE15AR	16	4	9.0	60	56.6	45	20		38.4	9.2							
PE15BR					76.0	35	35	M4 x 0.7 x 4.5	7.5	57.8	11.4	12.0	4.1	ø3	3.2	(3.3)	

Front view of PE type

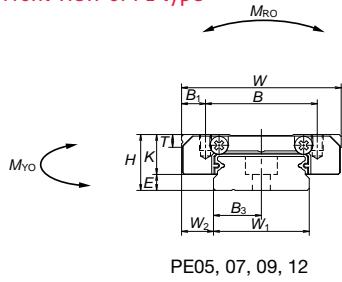

Side view of PE type

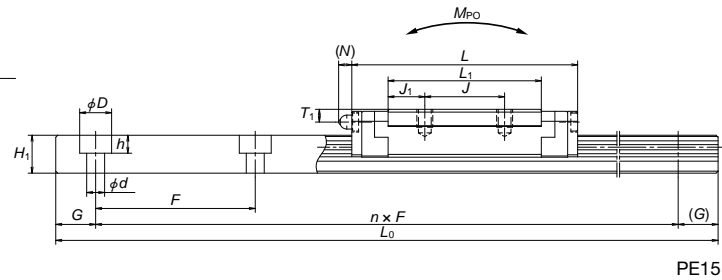
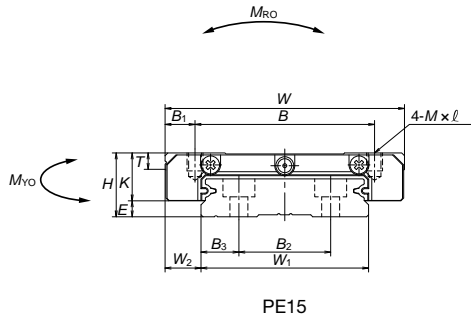
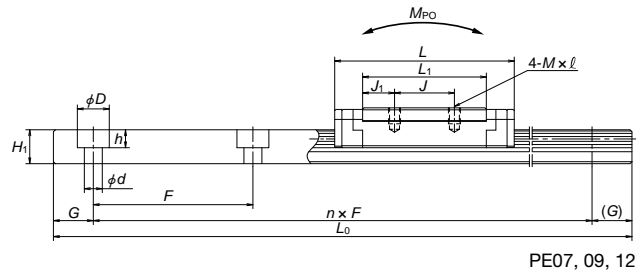

Rail of PE type

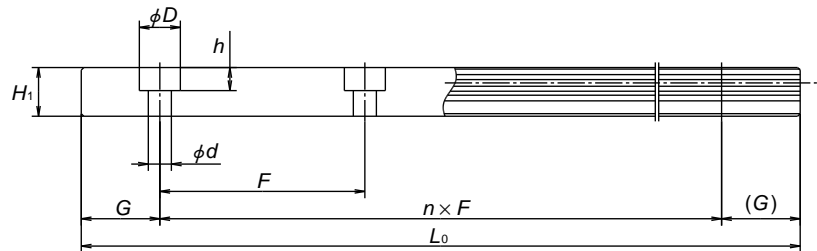
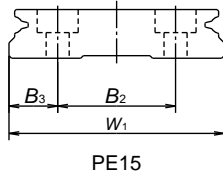
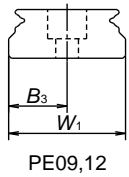

Unit: mm

Rail						Basic Load Rating							Weight	
Width W ₁	Height H ₁	B ₂	Pitch F	Mounting Bolt Hole d x D x h	Max Length L _{max}	Dynamic	Static	Static Moment				Roller Slide (g)	Rail (g/100mm)	
						C (N)	C ₀ (N)	M ₁₀	M _{po}		M _{yo}			
									One Slide	Two Slides	One Slide			Two Slides
9	5.5		20	3.5 x 6 x 4.5	600	1,490	2,150	9.9	6.1	41.0	6.1	41.0	16	35
						2,100	3,500	16.2	15.6	88.0	15.6	88.0	25	
18	7.5	-	30	3.5 x 6 x 4.5	800	3,000	4,500	36.5	17.3	113	17.3	113	35	95
						4,000	6,700	54.5	37.5	210	37.5	210	50	
12	7.5		25	3.5 x 6 x 4.5	800	2,830	3,500	21.1	11.4	73.5	11.4	73.5	32	65
						4,000	5,700	34.5	28.3	174	28.3	174	53	
24	8.5	-	40	4.5 x 8 x 4.5	1000	4,350	6,350	70.5	29.3	180	29.3	180	66	140
						5,800	9,550	106.0	63.5	345	63.5	345	98	
15	9.5		40	3.5 x 6 x 4.5	1000	5,550	6,600	49.5	25.6	190	25.6	190	59	105
						8,100	11,300	84.5	69.5	435	69.5	435	100	
42	9.5	23	40	4.5 x 8 x 4.5	1200	7,600	10,400	207.0	59	370	59.0	370	140	275
						10,300	16,000	320.0	135	740	135.0	740	211	

1) Need to specify G dimension on every order. Please contact your NSK representative with questions.

RA SERIES

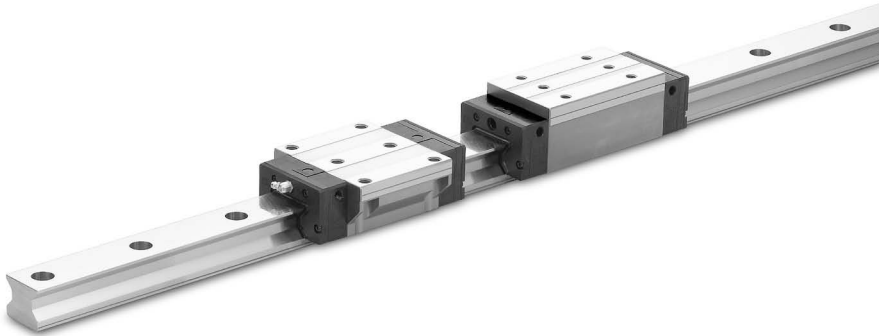

FEATURES:

Use rollers in place of balls as rolling elements to achieve the following:

- Super high load capacity.
- Smooth motion.
- Super high rigidity provides high precision manufacturing.
- Optimized recirculation reduces vibration and improves overall machining quality.
- Equipped with high performance seals to block entry of contaminants.
- Optional K1™ Lubrication Units provide maintenance-free operation.
- Inventory available in various sizes and models of ball slide to facilitate fast delivery.

RA SERIES NOMENCLATURE AND ACCESSORIES

INTERCHANGEABLE TYPE NOMENCLATURE

The rails and slides may be purchased separately or as an assembly for RA Series.

Reference Part Number for Interchangeable Assembly (Ball Slide + Rail)

RA	35	2000	EM		2	P6	Z	-	K1	F	20
SERIES NAME	SIZE	RAIL LENGTH (MM)	SHAPE/HEIGHT	MATERIAL/SURFACE TREATMENT Blank: Standard carbon steel	NUMBER OF BALL SLIDES PER RAIL A number must always be placed in this field including the need for only one slider	ACCURACY P6: P6 Accuracy Interchangeable Grade	PRELOAD/CLEARANCE Z: Preload		K1™ LUBRICATION SYSTEM Blank: No K1™ Lube Units K1: 1 K1™ Unit per side	FRANKLIN, INDIANA PRODUCTION	G1 DIMENSION Distance from the end of the rail to the center of the first bolt-hole 20=20mm

LINEAR GUIDE SLIDE AND RAIL NOMENCLATURE

Part Number Example for Roller Slide Only

RAA	35	AN	P	6	Z
INTERCHANGEABLE SERIES ROLLER SLIDE TYPE	SIZE	SHAPE/HEIGHT AN: Square (Tapped Holes) - Standard BN: Square (Tapped Holes) - Long EM: Flanged (Tapped & Thru Holes) - Standard GM: Flanged (Tapped & Thru Holes) - Long	K1™ LUBRICATION SYSTEM K: With K1™	ACCURACY P: P6 Accuracy	PRELOAD Z: Medium Preload (standard)

Reference Part Number for Rail Only

R1A	35	2000		Z	20
INTERCHANGEABLE SERIES RAIL TYPE	SIZE	RAIL LENGTH (MM)	MATERIAL/SURFACE TREATMENT Blank: Standard carbon steel	PRELOAD Z: For all rails (non-butting) -01Z: Butting rail	G1 DIMENSION Distance from the end of the rail to the center of the first bolt-hole 20=20mm

Note: NSK recommends the purchase of rail caps for use in harsh or contaminated environments. Reference (RA Series Accessories, below) to determine part number. Plastic and brass caps available.

ACCESSORIES

Plastic Cap for Rail Mounting Hole

Linear Guide Model No.	Rail Mounting Bolt Size	Cap. No. for Rail Mounting Hole
RA25	M6	L45800006-003
RA30	M8	L45800008-003
RA35	M8	L45800008-003
RA45	M12	L45800012-003
RA55	M14	L45800014-003
RA65	M16	L45800016-003

Brass Cap for Rail Mounting Hole

Linear Guide Model No.	Rail Mounting Bolt Size	Cap. No. for Rail Mounting Hole
RA25	M6	L45800006-004
RA30	M8	L45800008-004
RA35	M8	L45800008-004
RA45	M12	L45800012-004
RA55	M14	L45800014-004
RA65	M16	L45800016-004

Only standard products have been identified in this catalog. For complete listing of NSK linear guide product offerings, refer to e3162.

RA SERIES

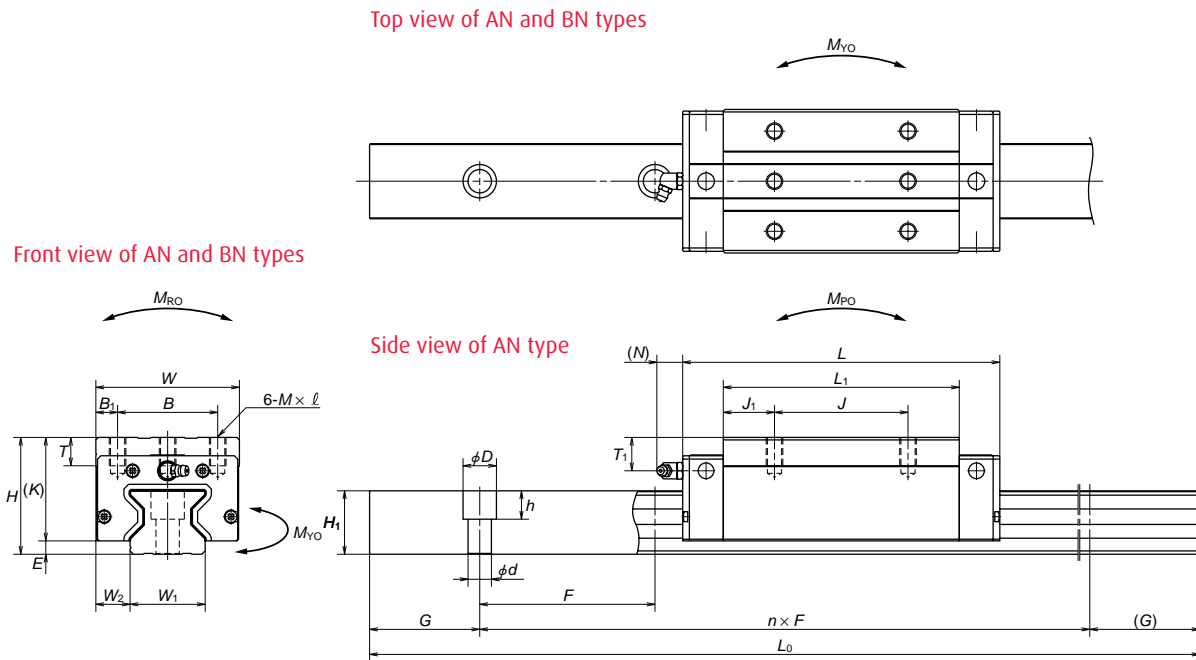

Model No.	Assembly					Ball Slide											
	Height H	E	W ₂	Width W	Length L	Mounting Hole			Q ₂	B ₁	L ₁	J ₁	K	T	Grease Fitting		
						B	J	M x pitch x l							Hole size	T ₁	N
RA25AN	40	5	12.5	48	97.5	35	35	M6 x 1 x 9	6.5	65.5	15.25	35.0	12	M6 x 0.75	10	11	
RA25BN					115.5		50			83.5	16.75						
RA30AN	45	6.5	16	60	110.8	40	40	M8 x 1.25 x 11	10	74.0	17.00	38.5	14	M6 x 0.75	10	11	
RA30BN					135.4		60			98.6	19.30						
RA35AN	55	6.5	18	70	123.8	50	50	M8 x 1.25 x 12	10	83.2	16.60	48.5	15	M6 x 0.75	15	11	
RA35BN					152.0		72			111.4	19.70						
RA45AN	70	8	20.5	86	154.0	60	60	M10 x 1.5 x 17	13	105.4	22.70	62.0	17	Rc1/8	20	14	
RA45BN					190.0		80			141.4	30.70						
RA55AN	80	9	23.5	100	184.0	75	75	M12 x 1.75 x 18	12.5	128.0	26.50	71.0	18	Rc1/8	21	14	
RA55BN					234.0		95			178.0	41.50						
RA65AN	90	13	31.5	126	228.4	76	70	M16 x 2 x 20	25	155.4	42.70	77.0	22	Rc1/8	19	14	
RA65BN					302.5		120			229.5	54.75						

Rail of AN and BN types

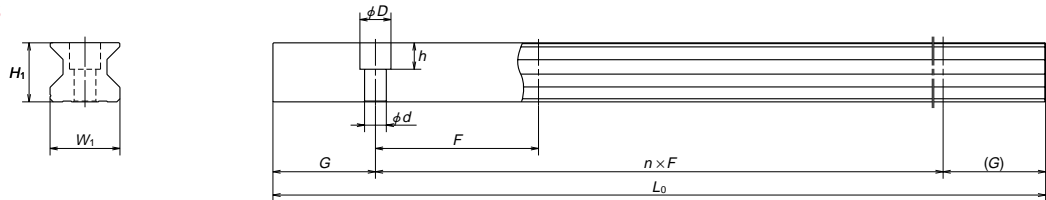

Unit: mm

Rail					Basic Load Rating								Weight	
Width W ₁	Height H ₁	Pitch F	Mounting Bolt Hole	Max Length L _{max}	Dynamic		Static	Static Moment						
					C ₅₀ [50km]	C ₁₀₀ [100km]	C ₀	M _{po}		M _{yo}				
			d x D x h	() for Stainless	(N)	(N)	(N)	M _{to}	One Slide	Two Slides	One Slide	Two Slides	Roller Slide (kg)	Rail (kg/m)
23	24	30	7 x 11 x 9	3000	36,000	29,200	72,700	970	760	4850	760	4850	0.60	3.4
					43,500	35,400	92,900	1240	1240	7200	1240	7200	0.91	
28	28	40	9 x 14 x 12	3500	47,800	38,900	93,500	1670	1140	7100	1140	7100	1.00	4.9
					58,500	47,600	121,000	2170	1950	11500	1950	11500	1.30	
34	31	40	9 x 14 x 12	3500	65,500	53,300	129,000	2810	1800	11000	1800	11000	1.60	6.8
					82,900	67,400	175,000	3810	3250	17800	3250	17800	2.10	
45	38	52.5	14 x 20 x 17	3500	114,000	92,800	229,000	6180	4080	24000	4080	24000	3.00	10.9
					143,000	116,000	305,000	8240	7150	39000	7150	39000	4.10	
53	43.5	60	16 x 23 x 20	3500	159,000	129,000	330,000	10200	7060	41000	7060	41000	4.90	14.6
					207,000	168,000	462,000	14300	13600	72000	13600	72000	6.70	
63	55	75	18 x 26 x 22	3500	259,000	210,000	504,000	19200	12700	78500	12700	78500	9.30	22.0
					355,000	288,000	756,000	28700	28600	153000	28600	153000	12.20	

1) Need to specify G dimension on every order. Please contact your NSK representative with questions.

RA SERIES

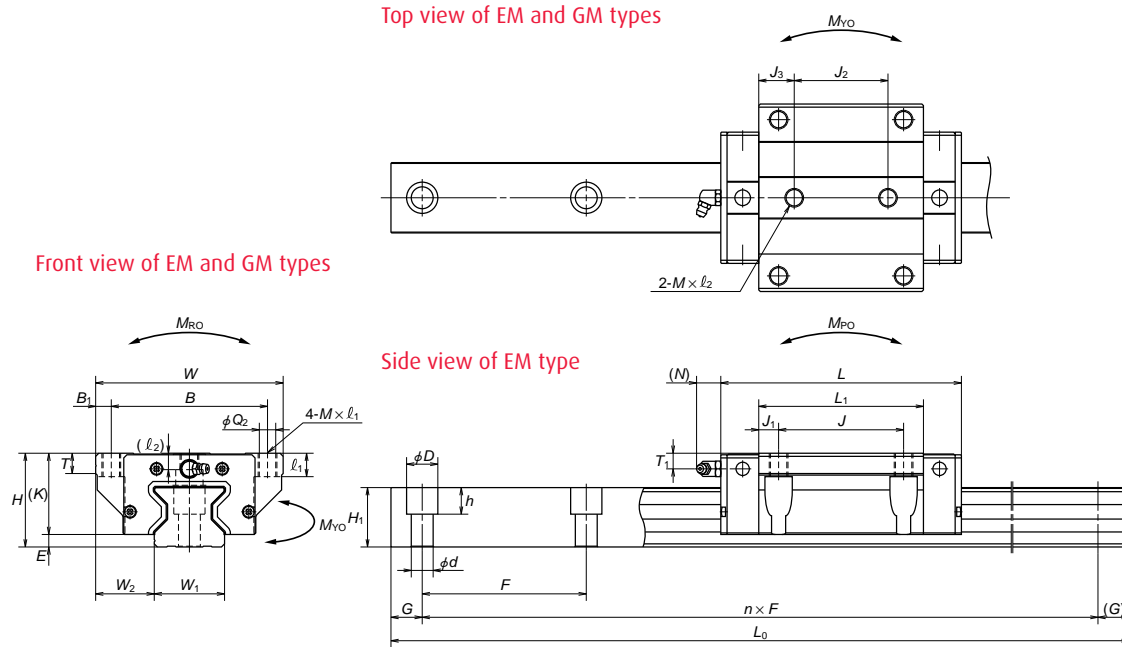

Model No.	Assembly					Ball Slide											
	Height H	E	W ₂	Width W	Length L	Mounting Hole			Q ₂	B ₁	L ₁	J ₁	K	T	Grease Fitting		
						B	J	M x pitch x ℓ							Hole size	T ₁	N
RA25EM	36	5	23.5	70	97.0	57	45	M8 x 1.25 x 10 (11)	6.8	6.5	65.5	10.25	31.0	11	M6 x 0.75	6	11
RA25GM					115.5						83.5	19.25					
RA30EM	42	6.5	31	90	110.8	72	52	M10 x 1.5 x 12 (12.5)	8.6	9.0	74.0	11.00	35.5	11	M6 x 0.75	7	11
RA30GM					135.4						98.6	23.30					
RA35EM	48	6.5	33	100	123.8	82	62	M10 x 1.5 x 13 (7)	8.6	9.0	83.2	10.60	41.5	12	M6 x 0.75	8	11
RA35GM					152.0						111.4	24.70					
RA45EM	60	8	37.5	120	154.0	100	80	M12 x 1.75 x 15 (10.5)	10.5	10.0	105.4	12.70	52.0	13	Rc1/8	10	14
RA45GM					190.0						141.4	30.70					
RA55EM	70	9	43.5	140	184.0	116	95	M14 x 2 x 18 (12)	12.5	12.0	128.0	16.50	61.0	15	Rc1/8	11	14
RA55GM					234.0						178.0	41.50					
RA65EM	90	13	53.5	170	228.4	142	110	M16 x 2 x 24 (18.5)	14.6	14.0	155.4	22.70	77.0	22	Rc1/8	19	14
RA65GM					302.5						229.5	59.75					

Rail of EM and GM types

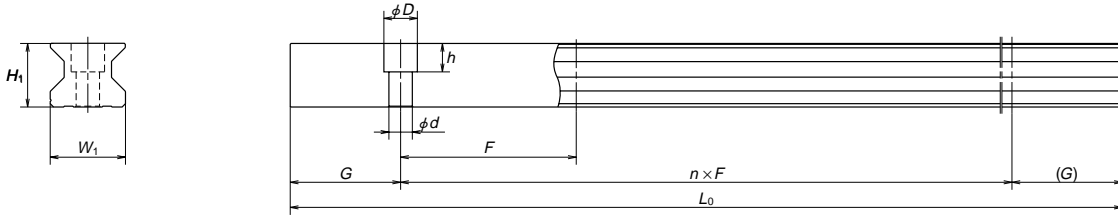

Unit: mm

Rail					Basic Load Rating								Weight		
Width W ₁	Height H ₁	Pitch F	Mounting Bolt Hole d x D x h	Max Length L _{max} () for Stainless	Dynamic		Static	Static Moment				Roller Slide (kg)			Rail (kg/m)
					C ₅₀ [50km]	C ₁₀₀ [100km]	C ₀	M _{po}		M _{yo}					
					(N)	(N)	(N)	M _{to}	One Slide	Two Slides	One Slide	Two Slides			
23	24.0	30	7 x 11 x 9	3000	36,000	29,200	72,700	970	760	4850	760	4850	0.80	3.4	
					43,500	35,400	92,900	1240	1240	7200	1240	7200	1.10		
28	28.0	40	9 x 14 x 12	3500	47,800	38,900	93,500	1670	1140	7100	1140	7100	1.30	4.9	
					58,500	47,600	121,000	2170	1950	11500	1950	11500	1.70		
34	31.0	40	9 x 14 x 12	3500	65,500	53,300	129,000	2810	1800	11000	1800	11000	1.70	6.8	
					82,900	67,400	175,000	3810	3250	17800	3250	17800	2.30		
45	38.0	52.5	14 x 20 x 17	3500	114,000	92,800	229,000	6180	4080	24000	4080	24000	3.20	10.9	
					143,000	116,000	305,000	8240	7150	39000	7150	39000	4.30		
53	43.5	60	16 x 23 x 20	3500	159,000	129,000	330,000	10200	7060	41000	7060	41000	5.40	14.6	
					207,000	168,000	462,000	14300	13600	72000	13600	72000	7.50		
63	55.0	75	18 x 26 x 22	3500	259,000	210,000	504,000	19200	12700	78500	12700	78500	12.20	22.0	
					355,000	288,000	756,000	28700	28600	153000	28600	153000	16.50		

1) Need to specify G dimension on every order. Please contact your NSK representative with questions.

ASSEMBLY AND MOUNTING

ASSEMBLY

Interchangeable ball slides are shipped on (disposable) plastic provisional rails as shown in Fig 8.

1. Wipe off anticorrosive oil from the rail.
2. NH, NS, RA & LW Series NSK slides come prepacked with Alvania 2 (AS2) grease for quick installation. PU/PE series slides have Multitemp PS2 grease.
3. Align the rail with the bottom and side faces of the provisional rail while pushing the provisional rail lightly against the rail, slide the ball slide on the rail (Fig 8).

Fig 8 Assembly of Ball Slide with Rail

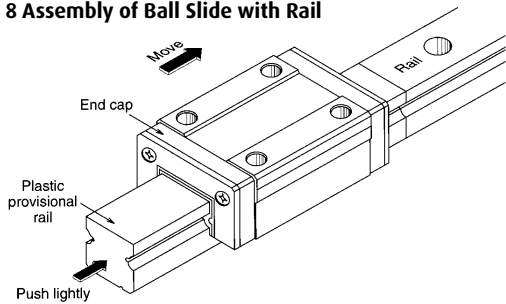

MOUNTING METHOD

Shoulder Height and Corner Shape at Mounting Face

When utilizing the reference surface to secure rail or ball slides to machine components the components must have the mounting face height (H' , H'') and corner chamfer (r) dimensions as listed in table below and illustrated in Figs. 9 and 10, to avoid interference.

Shoulder Height and Corner Shape at Mounting Face (values for NH Series)

Product No.	Radius of corner r (max)	Shoulder Height of Rail H'	Shoulder Height of Ball Slide H''
15	0.5	4.0	4.5
20	0.5	4.5	5.0
25	0.5	5.0	5.0
30	0.5	6.0	6.0
35	0.5	6.0	6.0
45	0.7	8.0	8.0
55	0.7	10.0	10.0
65	1.0	11.0	11.0

Fig 9 Rail Datum Face Mounting Part

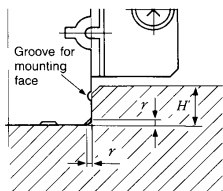
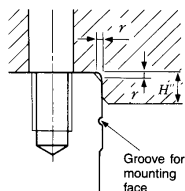

Fig 10 Ball Slide Datum Face Mounting Part



MOUNTING PROCEDURE

For Cases where Datum Surface Exists on the Bed

1. Lightly tighten the rail mounting bolts and then use the shoulder plate to secure rail datum surface against bed mounting surface (See Fig. 11).
2. Tighten rail mounting bolts to their recommended torque value (see table below). Tighten the bolts in an order which enables the wrench to help push the rail against the mounting surface (see Fig. 12 for example).
3. Mount the adjust side rail, as shown in Fig. 13, while checking rail parallelism. For the jig shown in Fig. 13, stability will be improved by mounting it to a ball slide.
4. If dowel pins are being used they should be installed at this step.
5. Position the ball slides at specified intervals and mount the table gently.
6. Tighten ball slide mounting bolts of datum side while pushing the table so that the table and ball slide mounting reference surfaces are in contact.

Fig 11 Positioning of Rail

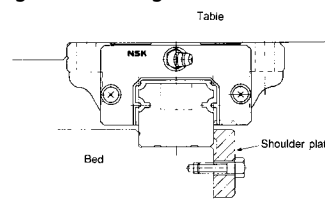

Recommended Torque for Rail Mounting Bolt (Case of Thermally Refined Bolt)

unit: kgf · cm

Bolt Nominal No.	Torque	Bolt Nominal No.	Torque
M3	10.8	M10	440
M4	25.0	M12	770
M5	52.0	M14	1240
M6	88.0	M16	2000
M8	220.0	--	--

[1 kg · cm=0.8681 lb in]

Fig 12 Tightening Direction

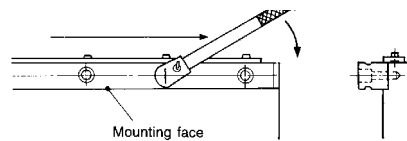
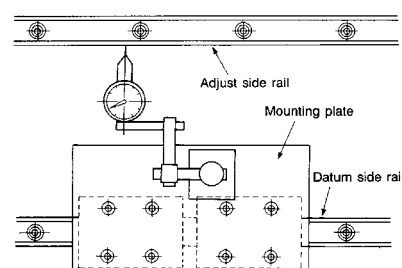

Fig 13 Parallelism Measurement with jigs



INDICATION OF INSTALLED DATUM SIDE

The datum face of each rail is indicated by a groove in the datum face or by an arrow mark on the end or top surface of the rail.

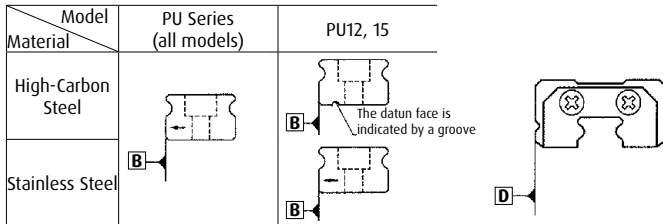
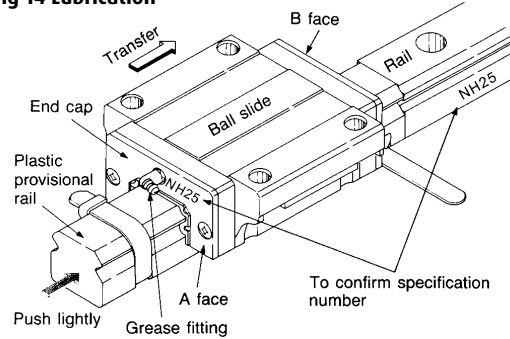

Fig 14 Lubrication



LUBRICATION

Grease Lubrication

NH, NS, LW & RA series linear guides are packed with Alvania 2 (AS2) grease. PU/PE series guides use Multitemp PS2 grease. All can be used as delivered. The replenishment frequency is recommended to be once a year, but adjust the interval depending on the operational conditions.

To Change Direction of Grease Fitting

1. Remove the grease fitting with a wrench.
2. Wind some sealing tape on the thread of the fitting, then insert it and tighten. Be careful not to over torque when tightening into the side of the plastic bearing end cap.

Change of Fitting Position in Front/Back Direction

1. Remove the plug from the grease fitting mounting hole face B shown in Fig. 14 with a hexagonal wrench.
2. Remove the grease fitting from face A and screw into hole face B.
3. In place of the removed fitting, insert the plug into the hole in the face A.

Change Grease Fitting Position to Side Surface

To mount the grease fitting on the end cap side face, or on the ball slide face, please consult NSK.

Oil Lubrication

Oil piping can be connected to the tapped hole from where the grease fitting was removed. The recommended lubrication oil supply quantity per ball slide per hour Q is given by the following formula, where N is the rail width number.

For NH, NS, LW, PU/PE:

$$Q = \frac{N}{150} \text{ (ml/hr)} \dots \dots \dots (5)$$

For RA:

$$Q = \frac{N}{100} \text{ (ml/hr)} \dots \dots \dots (5)$$

Using NH45 as an example, N=45, and

$$Q = \frac{45}{150} = 0.3 \text{ (ml/hr)}$$

Grease Fittings for NSK Ball Slides

Type	Linear Guide Model #	Grease Fitting Part #	Thread Spec.
Drive	NH 15, NS 15, LW 17	L50010000-301	Dia. 3mm
A	NS, NS 20, 25, 30, 25	L50000000-001	M6X0.75MM
B	NS, NS 20, 25, 30, 25	L50100000-001	M6X0.75MM
C	NS, NS 20, 25, 30, 25 LW 21, 27, 35	L50200000-001	M6X0.75MM
A	NH 45, 55, 65	L50003000-001	PT 1/8
B	NH 45, 55, 65	L50103000-001	PT 1/8
C	NH 45, 55, 65, LW 50	L50203000-001	PT 1/8

Shape of Grease Fitting

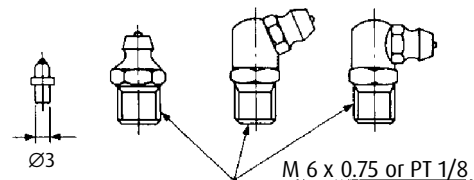

(1) Drive-in type A type B type C type

(1) Applies only to model No. NH15, NS15 and LW17.

GREASE

NSK GREASE UNIT

Replenish grease to NSK linear guides and ball screws by a manual type hand grease pump. Install the grease in bellows tube to the pump. Several types of grease (80 g) are available.



Grease in a bellows tube



COMPOSITION OF NSK GREASE UNIT

Components and grease types are shown below.

	Name	(tube type)	Reference Number
NSK Grease (80 g in a bellows tube)	NSK Grease AS2	(Brown)	NSK GRS AS2
	NSK Grease PS2	(Orange)	NSK GRS PS2
	NSK Grease LR3	(Green)	NSK GRS LR3
	NSK Grease LG2	(Blue)	NSK GRS LG2
NSK Hand Grease Pump Unit			NSK HGP
Straight nozzle NSK HGP NZ1 -- (One nozzle is provided with the hand pump.)			
Grease nozzle (used with the hand grease pump)			
	NSK straight nozzle		NSK HGP NZ1
	NSK chuck nozzle		NSK HGP NZ2
	NSK drive fitting nozzle		NSK HGP NZ3
	NSK point nozzle		NSK HGP NZ4
	NSK flexible nozzle		NSK HGP NZ5
	NSK flexible extension pipe		NSK HGP NZ6
	NSK straight extension pipe		NSK HGP NZ7

NSK GREASES (80 G IN A BELLOWS TUBE)

Bellows tube

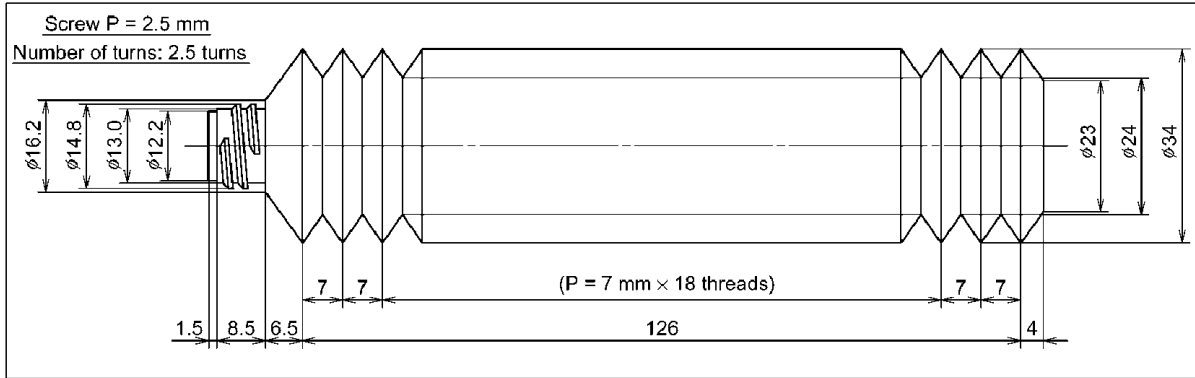

NSK MANUAL GREASE PUMP UNIT

NSK Hand Grease Pump Unit (Reference number: NSK HGP)

Features

- Light-weight Can be operated by one hand yet there is no worry of making a mistake.
- Inserting by high pressure Insert at 15 Mpa.
- No leaking Does not leak when held upside down.
- Easy to change grease Simply attach the grease in bellows tube.
- Remaining grease Can be confirmed through slit on the tube.
- Several nozzles Five types of nozzles to choose from.

Specifications

- Spout volume 0.35 cc/stroke
- Mass of main body 240g without nozzle, provided nozzle 90g
- Accessory Several nozzles for a unique application can be attached

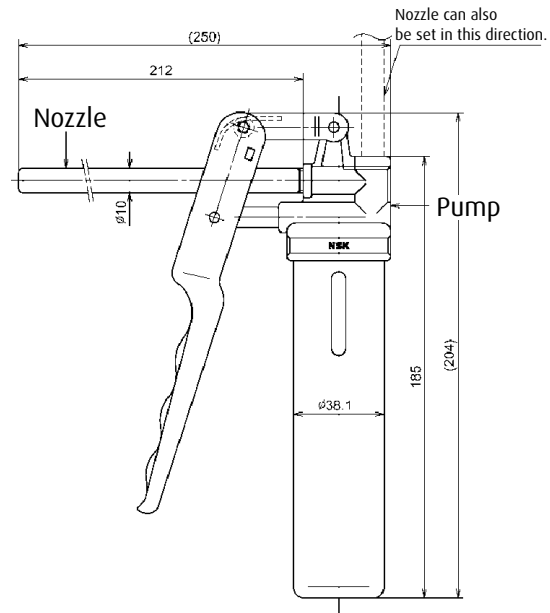

Fig 15 NSK Hand Grease Pump with NSK straight nozzle

GREASE (CONT)

NOZZLES

Nozzles that can be attached to NSK Hand Grease Pump

Name	Designation Code	Use	Dimensions
NSK straight nozzle	NSK HGP NZ1	Can be used with grease fitting A, B, and C under JIS B1575 standard.	
NSK chuck nozzle	NSK HGP NZ2	Can be used with grease fitting A, B, and C under JIS B1575 standard.	
NSK fitting nozzle	NSK HGP NZ3	Dedicated for the -03 drive-in grease fitting.	
NSK point nozzle	NSK HGP NZ4	Used for linear guides and ball screws which do not have grease fitting. Used to supply grease directly to the ball grooves, or through the opening of ball slide or ball slide to inside.	
NSK flexible nozzle	NSK HGP NZ5	Tip of nozzle is flexible to supply grease in the areas where hand cannot reach.	
NSK flexible extension pipe	NSK HGP NZ6	Flexible extension pipe connects the grease pump and the nozzle.	
NSK straight extension pipe	NSK HGP NZ7	Straight extension pipe connects the grease pump and the nozzle.	

GREASE LUBRICANT FOR LINEAR GUIDES AND BALL SCREWS

Type	Thickener	Base Oil	Base Oil Kinematic Viscosity cSt (40°C)	Range of use Temperature (°C)	Purpose
AS2	Lithium type	Mineral oil	130	-10 ~110	For general use at high load.
PS2	Lithium type	Synthetic oil + mineral oil	15.9	-50 ~110	For low temperature and high frequency operation.
LR3	Lithium type	Synthetic oil	30	-30 ~130	For high speed, medium load.
LG2	Lithium type	Mineral oil + synthetic hydrocarbon oil	32	-20 ~70	For clean room environment.
NF2	Urea composite type	Synthetic oil + mineral oil	26	-40 ~100	For fretting resistance.

GREASE NOZZLE USED FOR NSK LINEAR GUIDE

Linear Guide Model	Tap Hole for Grease Fitting	Standard Grease Fitting	Straight Nozzle NZ1	Chuck Nozzles (two) NZ	Drive-in Nipple Nozzles NZ3	Point Nozzle NZ4	Flexible Nozzle NZ5
NH15	ø3	Drive-in type			●		
NH20~35 ⁽¹⁾	M6 x 0.75	B type	●	●			●
NH45~65	Rc1/8	B type	●	●			●
NS15	ø3	Drive-in type			●		
NS20~35 ⁽¹⁾	M6 x 0.75	B type	●	●			●
LW17	ø3	Drive-in type			●		
LW21~35	M6 x 0.75	B type	●	●			●
LW50	Rc1/8	B type	●	●			●
PU05~12	-	None				● ⁽²⁾	
PU15	ø3	Drive-in type			●		
PE05~12	-	None				● ⁽²⁾	
PE15	ø3	Drive-in type			●		
RA 25~35	M6 x 0.75	B type	●	●			●
RA 45~65	Rc1/8	B type	●	●			●

1) NS20, NS25, NH20: Use straight nozzle. (Point nozzle tip cannot be used because it interferes with the rail top surface).

2) PU and PE Series: Apply grease directly to ball groove, etc. using a point nozzle.

FIGURES OF GREASE FITTINGS

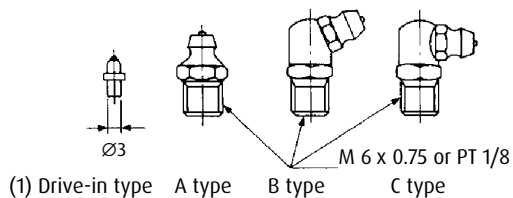

APPLICATION SHEET

LINEAR GUIDE – RAIL BUTTING

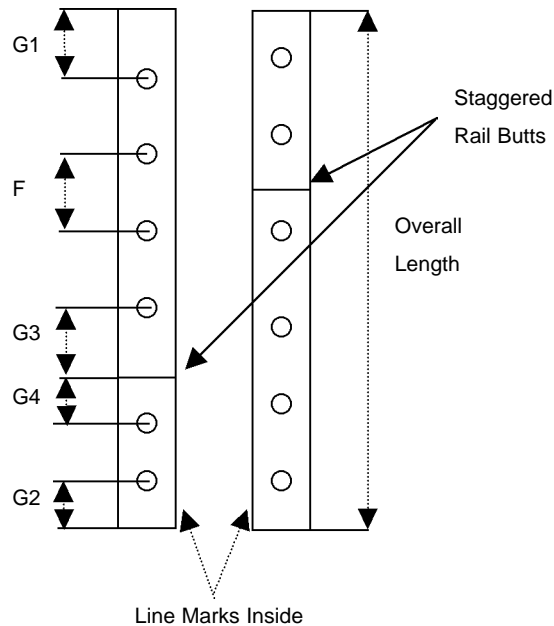

In order to determine rail butting configuration, please photocopy and complete this form from our catalog and fax back to NSK. An electronic copy is available, please contact our customer service.

Quantity _____ Rail Number: _____

G1 Dimension: _____ mm G2 Dimension: _____ mm

Note 1: For butting rails only.

Note 2: Make sure line marks are inside for Rail Butting.

Consists of _____ G1 = _____ G3 = _____
 _____ G2 = _____ G4 = _____

Company: _____

Contact Name: _____

Telephone: _____ Fax: _____

Date: _____ E-Mail: _____

Remarks: _____



NSK AMERICAS

Argentina

NSK Argentina SRL
Buenos Aires
54.11.4762.6556

Brazil

NSK Brasil Ltda.
Sao Paulo SP
55.11.3269.4700

Canada

NSK Canada Inc.
Mississauga ON
1.877.994.6675

Latin America

NSK Latin America Inc.
Miami FL
1.305.477.0605

Mexico

NSK Rodamientos Mexicana, S.A. de C.V.
Tlaine pantla de Baz MX
52.55.3682.2900

United States

NSK Corporation
Ann Arbor MI
1.888.446.5675

Website: www.nskamericas.com

NSK Global: www.nsk.com

Every care has been taken to ensure the accuracy of the data contained in this brochure, but no liability can be accepted for any loss or damage suffered through errors or omissions.

Printed in the USA ©NSK 2017. The contents of this publication are the copyright of the publishers.